

McCANNALOK SERIES

HIGH PERFORMANCE BUTTERFLY VALVES

TECHNICAL SALES GUIDE (ASME 150 | 300 | 600)

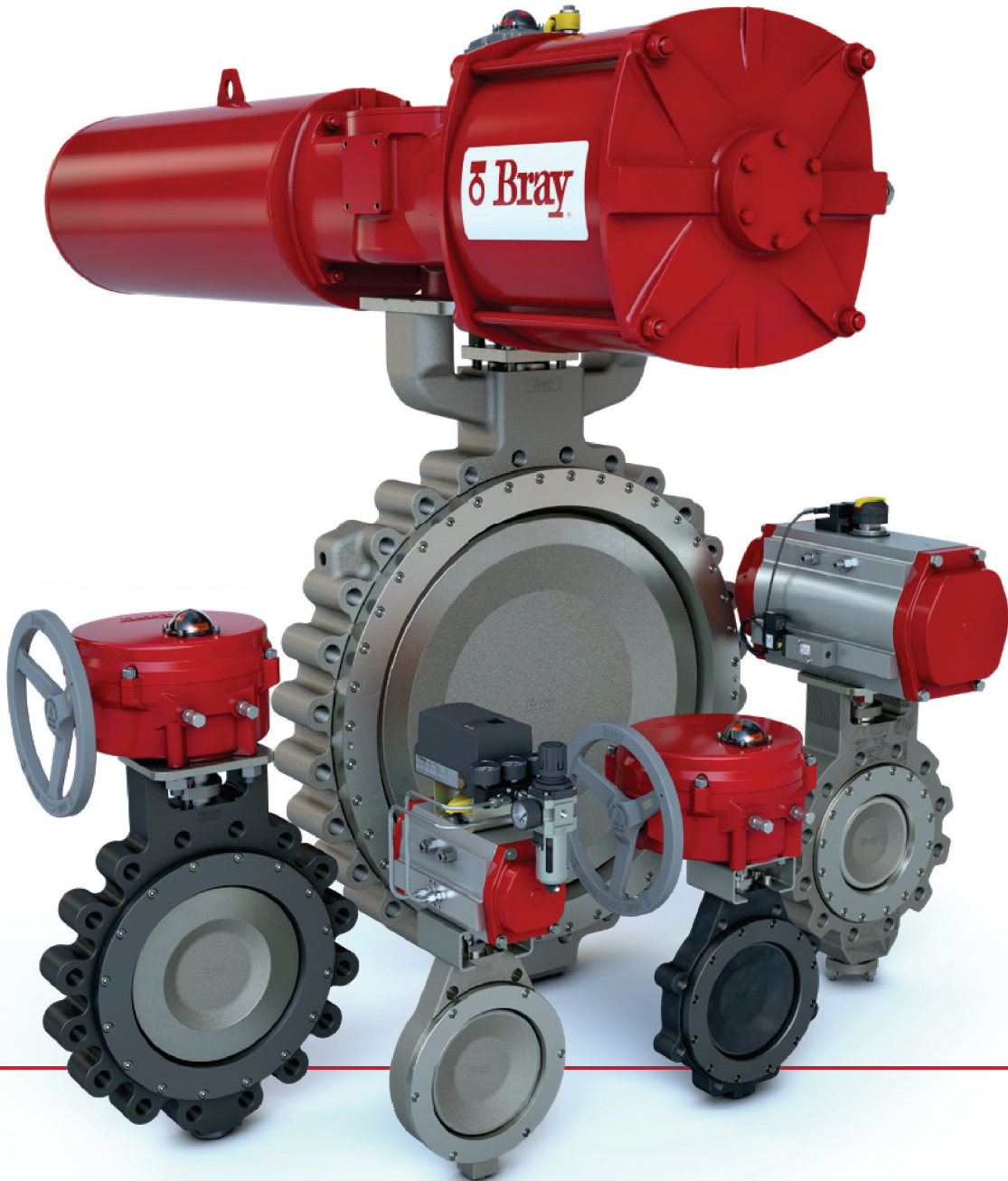

Bray[®]

BRAY.COM

THE HIGH PERFORMANCE COMPANY

Table of Contents

OVERVIEW 3

TECHNICAL DATA 4

FEATURES & BENEFITS 5

SEAT OPTIONS 6

AVAILABLE SIZES (NPS & DN) 7

VALVE SELECTION 8

MATERIALS OF CONSTRUCTION (PARTS CALLOUT) 9

MATERIALS OF CONSTRUCTION (PARTS LIST) 10

PRESSURE/TEMPERATURE (psig/°F) 11

PRESSURE/TEMPERATURE (bar/°C) 12

DIMENSIONS AND WEIGHTS (in & lb) 13

DIMENSIONS AND WEIGHTS (mm & kg) 18

SEATING/UNSEATING TORQUES (Lb-in) 23

SEATING/UNSEATING TORQUES (Nm) 27

MAXIMUM ALLOWABLE STEM TORQUES (Lb-in & Nm) 31

DYNAMIC TORQUES 32

DYNAMIC TORQUE COEFFICIENT 33

SUBCHOKED AND CHOKED FLOW 34

SUBCHOKED AND CHOKED FLOW 35

VALVE SIZING COEFFICIENTS (Cv VALUES) 36

VALVE SIZING COEFFICIENTS (Kv VALUES) 37

FLANGE TO VALVE BOLTING DATA | WITH WASHERS (in & mm) 38

FLANGE TO VALVE BOLTING DATA | NO WASHERS (in & mm) 44



For information on this product and other Bray products please visit us at www.bray.com



HIGH PERFORMANCE BUTTERFLY VALVE

Featuring Bray’s patented, award-winning design, this double offset high performance butterfly valve is precision engineered to deliver **quality, value,** and **reliability** in the most demanding applications.

- > Designed for high pressure, high temperature, and critical service applications.
- > Energized resilient seat design provides bidirectional zero-leakage shutoff throughout full pressure range.
- > Dead-end service, with bidirectional sealing.
- > Available firesafe design.
- > Low fugitive emissions.
- > Metal seated control valve available.
- > Easy field maintenance.
- > Low torque requirements allow smaller actuators than comparably rated valves.
- > Direct mounting of Bray actuators and controls provides a strong mechanical connection and allows economical automation.
- > Available high cycle configuration, rigorously tested to 1 million cycles.

DOUBLE OFFSET STEM AND DISC DESIGN

The disc motion of the double offset design provides many performance benefits:

DISC OPENING

- > Cam-action movement pulls disc away from seat.
- > Reduces seat wear.

OPEN POSITION

- > Disc does not contact seat.
- > Eliminates seat deformation.
- > Reduces operating torques.
- > Extends service life.

DISC CLOSING

- > Linear motion pushes disc onto seat.
- > Wiping action prevents undesirable material buildup.

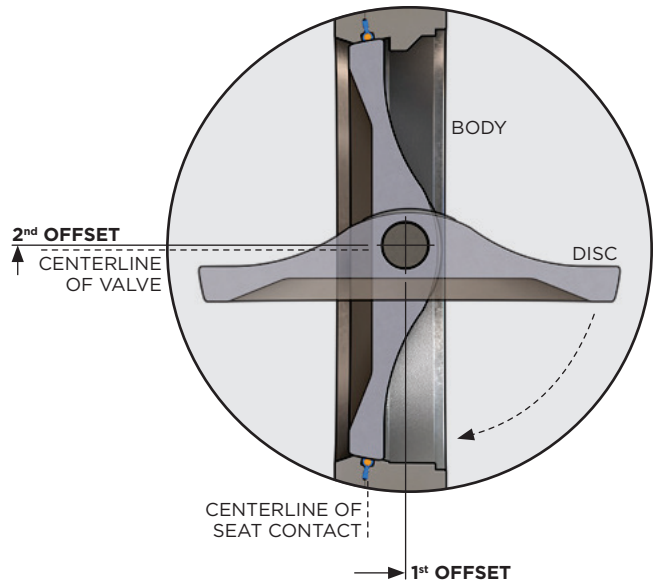

INDUSTRIES

- > Air Separation
- > Chemical
- > Data Centers
- > Electric Power Generation
- > Heating, Ventilation & Air Conditioning (HVAC)
- > Metal Processing
- > Mining
- > Oilfield
- > Petrochemical
- > Petroleum
- > Shipbuilding
- > Water & Wastewater Treatment

APPLICATIONS

- > Caustic
- > Chilled Water
- > Pressure Swing Adsorption (PSA)
- > Seawater
- > Sour Gas (NACE)
- > Steam
- > Vacuum

MEDIA

- > Acids
- > Alkalis
- > Corrosive Chemicals
- > Dry Chlorine (Gas or Liquid)
- > Gases
- > Hydrogen
- > Oxygen
- > Water

SPECIFICATIONS

Size Range	NPS 2 to 66	
	DN 50 to 1500	
Body Style	Wafer Lug Double Flanged	
Temperature Range	Resilient Seated	-62 to 500°F
		-52 to 260°C
	Firesafe	-62 to 500°F
		-52 to 260°C
	Metal Seated	up to 900°F
		up to 482°C
Pressure Ratings	ASME Class 150 300 600	
	PN 10 16 25 40 63 100	
Leakage Rate	Resilient Seated	Zero Leakage
	Metal Seated	FCI 70-2 Class IV

MATERIAL OPTIONS

Body Materials	Carbon Steel
	Stainless Steel
	Nickel Aluminum Bronze
	Hastelloy® C
	Titanium
Disc Materials	Stainless Steel
	Nickel Aluminum Bronze
	Monel®
Stem Materials	Stainless Steel
	Monel® K500
	Inconel® 718
Seat Materials	RPTFE with Resilient Energizer
	PTFE with Resilient Energizer
	UHMWPE with Resilient Energizer
	TFM with Low Temperature Resilient Energizer
	(Firesafe) Inconel® & RPTFE with Resilient Energizer

NOTE

> Other materials are available on request. Contact Bray for more information.

DESIGN STANDARDS

Valve Design	ASME B16.34
	MSS SP 68
	ASME VIII
	API 609 Category B
	EN 593
	EN 12516
Top Flange	ISO 5211
Flange Drilling¹	ASME B16.5
	ASME B16.47
	EN 1092-1

Seat Tightness Test	API 598
	MSS SP 61
	EN 12266
	ISO 5208
Face-to-Face	ASME B16.10
	API 609 Category B
	EN 558
	ISO 5752

NOTE

¹ Additional flange drilling options available.

CERTIFICATIONS & APPROVALS

Certifications	ANSI/NSF 61/372
	CE: PED 2014/68/EU
	SIL
Fire Test	API 607
	ISO 10497
Fugitive Emissions	API 641
	ISO 15848-1
	TA-Luft VDI 2440

Approvals	ABS Type
	ATEX 2014/34/EU
	Bureau Veritas Type
	China Classification Society (CCS) Type
	CRN
	DNV
	EC1935
TR CU (GOST)	

NOTE

> A complete listing of certifications and approvals can be found at BRAY.COM.

DESIGN FEATURES

- 1 STEM DESIGN:** High-strength, one-piece stem design is standardized for interchangeability of Bray actuators.
- 2 BLOWOUT-PROOF STEM:** The stem retention design does not rely on actuation components to prevent stem blowout.
- 3 ADJUSTABLE STEM PACKING:** Easy access allows simple quarter-turn field adjustments without actuator removal.
- 4 STEM SEAL SYSTEM:** PTFE packing rings with carbon fiber anti-extrusion ring provides constant compression for a positive seal around the stem. Options are available for high temperature, high cycle and firesafe applications.
- 5 STEM BEARINGS:** Top and bottom bearings securely support the stem, provide excellent corrosion resistance, and minimize deflection from high temperatures and mechanical loading forces.
- 6 DISC:** The disc is engineered to maximize flow and minimize resistance for optimal Cv / Kv values.
- 7 INTERNAL OVER-TRAVEL STOP:** Designed to minimize possible seat damage — extending the service life of the seat.
- 8 BIDIRECTIONAL RESILIENT SEAT:** Provides bidirectional zero-leakage sealing while isolating the energizer from line media. (Firesafe option available.)
- 9 FULL-FACED SEAT RETAINER:** Cap screws located outside sealing area are protected from corrosion while allowing simple seat replacement.
- 10 BODY:** Extended neck allows access to stem packing adjustments and actuator mounting when valve is fully insulated.
- 11 DEAD-END SERVICE:** Lug and double-flanged bodies are full rated for bidirectional dead-end service.

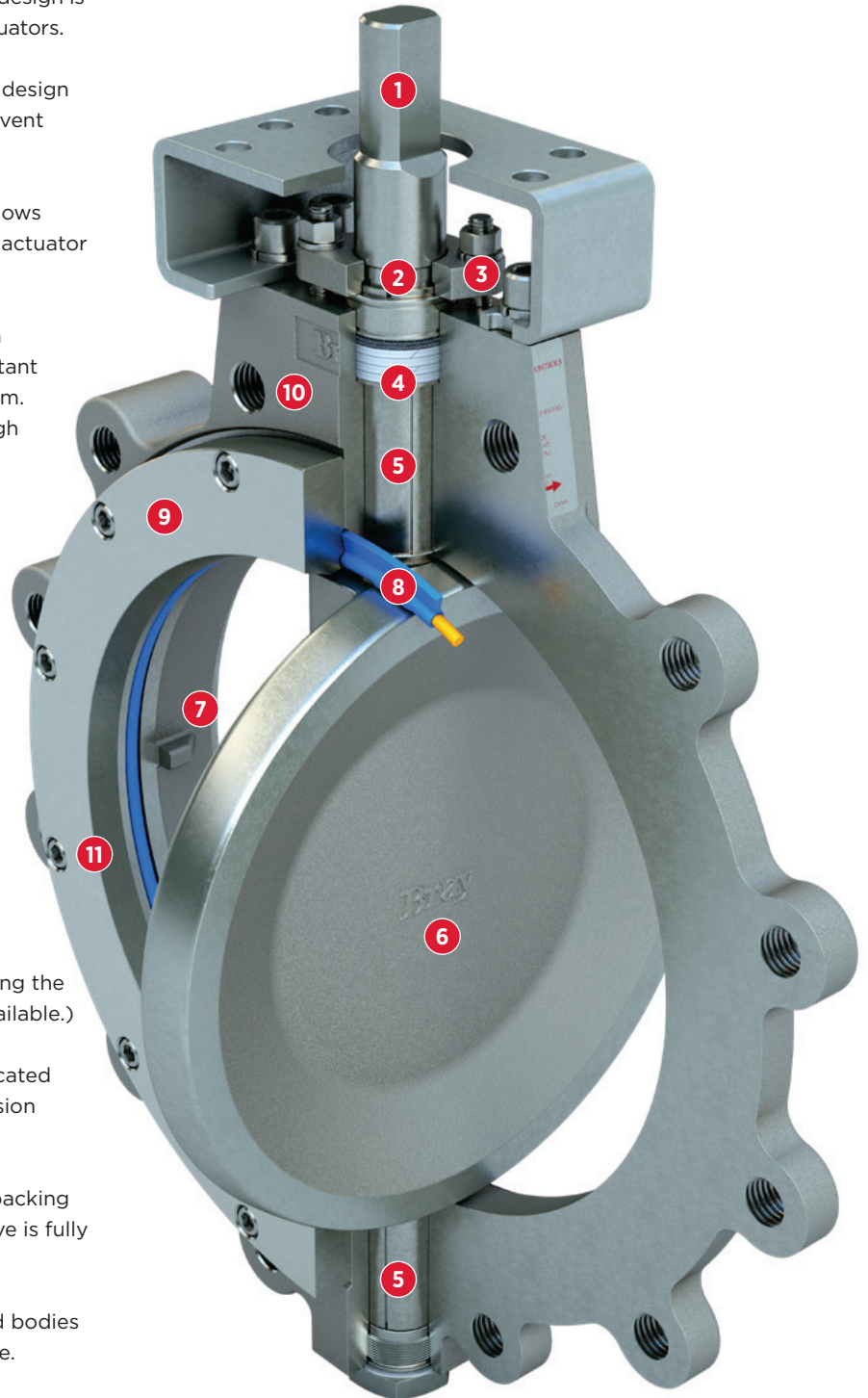

Series 41 Lug Style

BIDIRECTIONAL SEAT DESIGN (STANDARD)

Bray’s unique, patented resilient seat design offers many exclusive advantages:

- > Proven zero-leakage shutoff in both directions.
- > Interference-fit sealing, even when there is no differential line pressure.
- > Pressure-assisted sealing is energized by line media pressure, providing a tighter seal in higher differential pressure services.
- > Extended service life with reliable sealing after 1 million cycles.
- > Resilient energizer ring is fully encapsulated by the seat and isolated from all line media contact.
- > Full-faced retainer secures seat in the correct position, even without mating flange.
- > Seat self-adjusts for wear and temperature changes, providing longer service life.
- > Simplified seat replacement.

INTERFERENCE-FIT SEALING

Provides bidirectional sealing for low pressure applications.

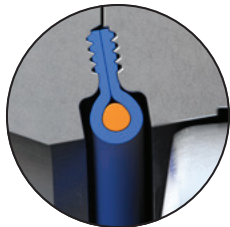

Seat Non-Compressed.
Disc approaches.

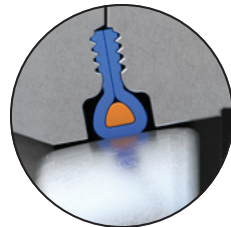

Disc in Closed Position.
No line pressure.

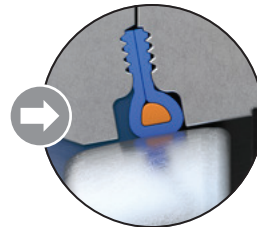

Disc in Closed Position.
Line pressure applied from the **preferred** flow direction.

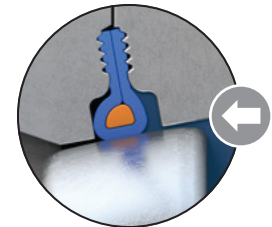

Disc in Closed Position.
Line pressure applied from the **non-preferred** flow direction.

PRESSURE-ASSISTED SEALING

Provides tighter bidirectional sealing in higher pressure applications.

FIRESAFE SEAT DESIGN

The available firesafe seat design adds an Inconel® metal seat to the bidirectional resilient seat assembly. With the valve closed, the firesafe seat assembly contacts the disc with both the resilient seat and metal seat. During and after a fire, when the resilient material has been partially or completely destroyed, the metal seat provides a bidirectional seal by remaining in contact with the disc.

Disc in Closed Position

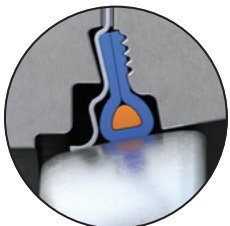

No line pressure.
(Pre-fire event condition.)

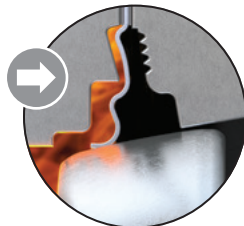

Line pressure applied from **preferred** flow direction.
(During or after fire event.)

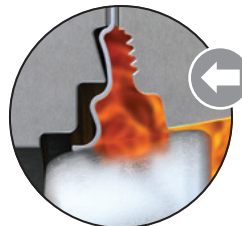

Line pressure applied from **non-preferred** flow direction.
(During or after fire event.)

METAL SEAT DESIGN

Inconel® metal seat provides FCI 70-2 Class IV leakage in both the preferred and non-preferred directions. The seat and nitride hardened disc have a large difference in hardness, which eliminates the risk of the sealing elements galling each other and damaging the valve.

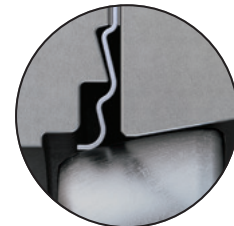

Disc in Closed Position.
No line pressure.

FIRE TEST STANDARDS — API 607 Certified

Bray’s proven firesafe valve design meets or exceeds the latest international fire test standards — in lab tests and in field applications.

ASME CLASS 150 — SERIES 40/41/4A
Up to 285 psi (19.6 bar)



VALVE SIZES (NPS)				
Model	Body Style	Standard	Firesafe	Metal Seated
40	Wafer	2 to 66	2 to 48	2½ to 30
41	Lug	2 to 66	2 to 48	2½ to 30
4A	Double Flanged	2 to 54	2 to 48	2½ to 30

VALVE SIZES (DN)				
Model	Body Style	Standard	Firesafe	Metal Seated
40	Wafer	50 to 1650	50 to 1200	65 to 750
41	Lug	50 to 1650	50 to 1200	65 to 750
4A	Double Flanged	50 to 1350	50 to 1200	65 to 750

ASME CLASS 300 — SERIES 42/43/4B
Up to 740 psi (51 bar)

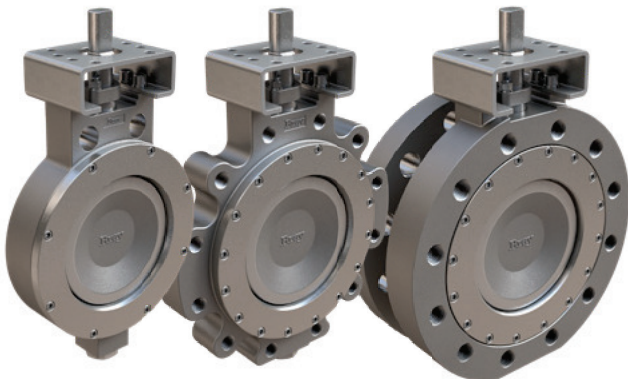

VALVE SIZES (NPS)				
Model	Body Style	Standard	Firesafe	Metal Seated
42	Wafer	2 to 36	2 to 36	2½ to 30
43	Lug	2 to 54	2 to 36	2½ to 30
4B	Double Flanged	3 to 42	2 to 36	2½ to 30

VALVE SIZES (DN)				
Model	Body Style	Standard	Firesafe	Metal Seated
42	Wafer	50 to 900	50 to 900	65 to 750
43	Lug	50 to 1350	50 to 900	65 to 750
4B	Double Flanged	80 to 1050	50 to 900	65 to 750

ASME CLASS 600 — SERIES 44/45
Up to 1440 psi (100 bar)



VALVE SIZES (NPS)				
Model	Body Style	Standard	Firesafe	Metal Seated
44	Wafer	3 to 24	3 to 24	6 to 12
45	Lug	3 to 36	3 to 36	6 to 12

VALVE SIZES (DN)				
Model	Body Style	Standard	Firesafe	Metal Seated
44	Wafer	80 to 600	80 to 600	150 to 300
45	Lug	80 to 900	80 to 900	150 to 300

PARTS CALLOUT

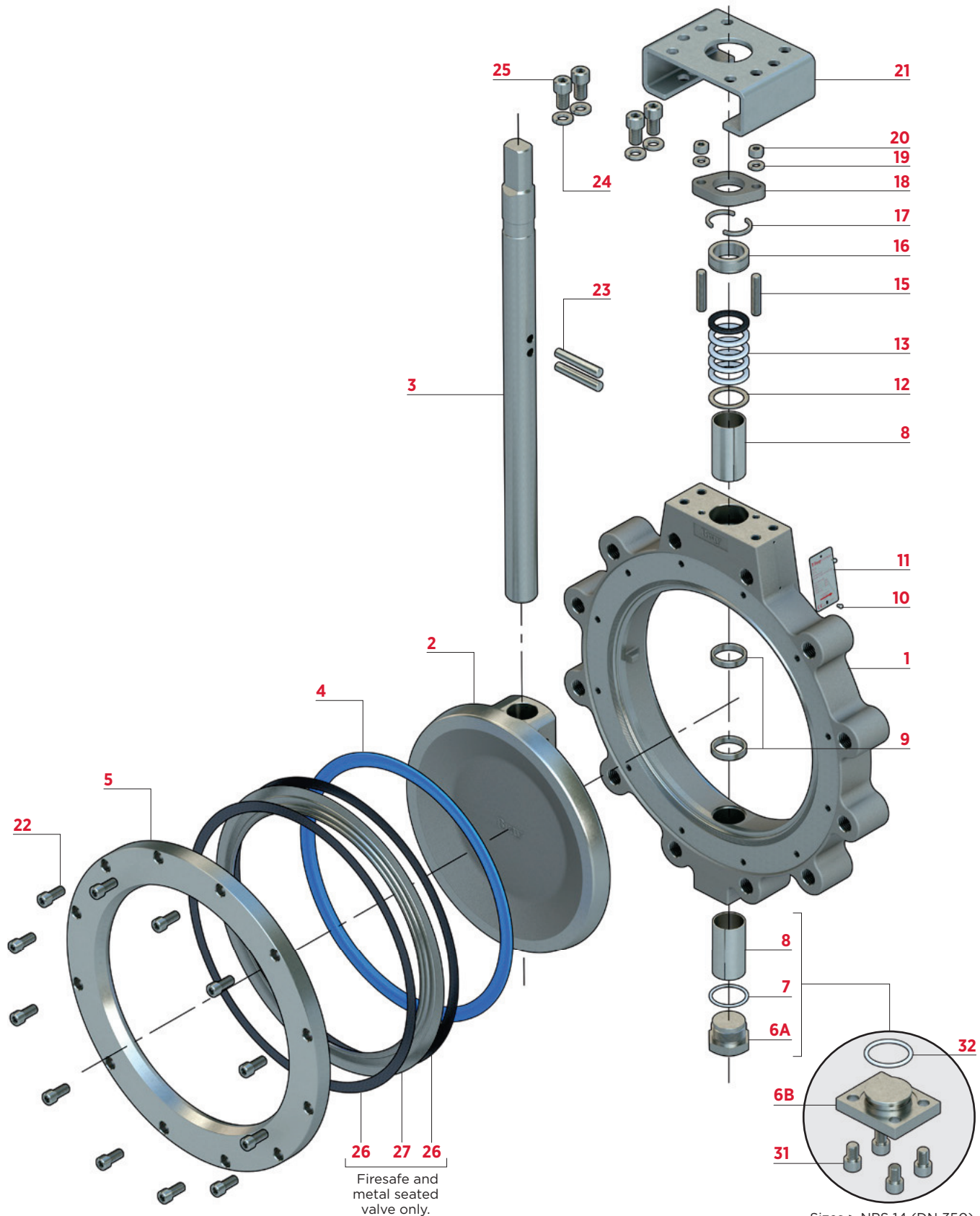

Sizes ≥ NPS 14 (DN 350)

PARTS LIST AND MATERIAL SPECIFICATIONS

ITEM	DESCRIPTION	MATERIAL	
		Standard	Optional
1	Body	Carbon Steel, ASTM A216 Gr. WCB/A516 Gr. 70	Nickel Aluminum Bronze, ASTM B-148 C95800
		Stainless Steel, ASTM A351 Gr. CF8M	
2	Disc	Stainless Steel, ASTM A351 Gr. CF8M	Nickel Aluminum Bronze, ASTM B-148 C95800
			Electroless Nickel Plating ³
3	Stem	17-4 PH Stainless Steel, ASTM A564-Type 630	Monel [®] K500
			316 Stainless Steel, ASTM 276 Type 316/A240-316 ¹
			Inconel [®] 718
4	Seat Assembly	RPTFE ² with Resilient Energizer	PTFE with Resilient Energizer
			TFM with Low Temperature Resilient Energizer
			Inconel [®] 718 & RPTFE ² with Resilient Energizer ³
5	Seat Retainer	Carbon Steel, ASTM A216 Gr. WCB/A516 Gr. 70	Nickel Aluminum Bronze, ASTM B-148 C95800
		Stainless Steel, ASTM A351 Gr. CF8M	
6A	Locating Plug	316 Stainless Steel, ASTM 276 Type 316/A240-316	—
6B	Bottom Plate	Carbon Steel, Phosphate Coated	—
		316 Stainless Steel, ASTM 276 Type 316/A240-316	
7	Gasket, Locating Plug	PTFE	Flexible Graphite ³
8	Bearing	316 Stainless Steel with Glass Fiber Reinforced PTFE Liner	Nitride Hardened Stainless Steel ³
9	Disc Spacers	316 Stainless Steel, ASTM 276 Type 316	Nitronic [®] 60 ⁴
10	Drive Screw	18-8 Stainless Steel	—
11	ID Tag	18-8 Stainless Steel	—
12	Thrust Washer	316 Stainless Steel, ASTM 276 Type 316	—
13	Stem Seal Set	PTFE rings + 1 Carbon Fiber Ring	Flexible Graphite Rings ³
			Carbon and Graphite Filled PTFE ⁴
14	Ground Washer	—	316 Stainless Steel (not shown)
15	Stud	316 Stainless Steel, ASTM A193-B8M	—
16	Gland Ring	316 Stainless Steel, ASTM 276 Type 316	—
17	Retaining Ring	18-8 Stainless Steel	—
18	Gland Retainer	316 Stainless Steel	—
19	Lock Washers or Belleville Washers ⁴	18-8 Stainless Steel	17-7 Stainless Steel
20	Hex Nut	18-8 Stainless Steel	—
21	Mounting Bracket	Carbon Steel, Zinc Plated	316 Stainless Steel
22	Cap Screws	18-8 Stainless Steel	Alloy Steel
23	Taper Pins	17-4 PH Stainless Steel, ASTM A564-Type 630	Monel [®] K500
24	Lock Washers	18-8 Stainless Steel	Alloy Steel
25	Cap Screws	18-8 Stainless Steel	Alloy Steel
26	Gasket ³	—	Flexible Graphite ³
27	Metal Seat ³	—	Inconel [®] 718, ASTM B670 ³
31	Cap Screws	18-8 Stainless Steel	Alloy Steel
32	Gasket, Bottom Plate	PTFE	—

NOTES

> Material specifications provided for reference only, and are subject to change without notice.

> Additional materials available upon request.

1 May require pressure rating to be reduced. Contact Bray for more information.

2 RTFE is supplied by Bray as RPTFE (reinforced polytetrafluoroethylene.)

3 Firesafe and metal seated valve only.

4 Used in high cycle configuration.

ASME CLASS 150 — SERIES 40/41/4A
STANDARD / FIRESAFE / METAL SEATED

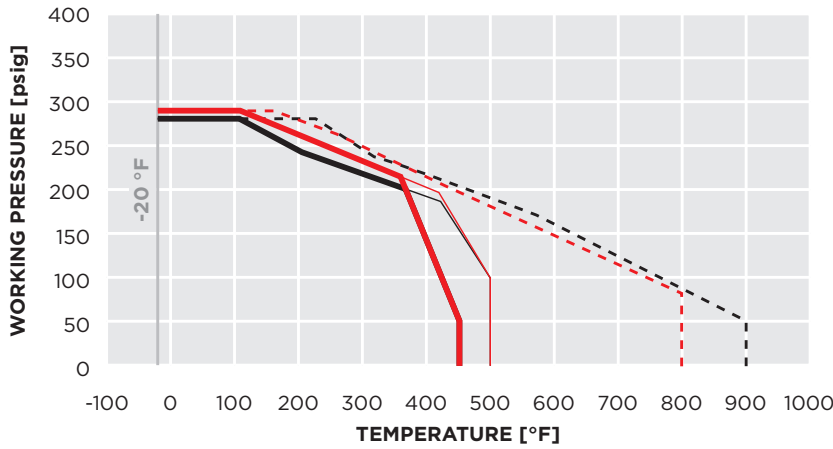

LEGEND (psig/°F)	
	Carbon Steel Body / RPTFE Seat
	Stainless Steel Body / RPTFE Seat
	Carbon Steel Body / PTFE Seat
	Stainless Steel Body / PTFE Seat
	Carbon Steel Body / Inconel Seat
	Stainless Steel Body / Inconel Seat

ASME CLASS 300 — SERIES 42/43/4B
STANDARD / FIRESAFE / METAL SEATED

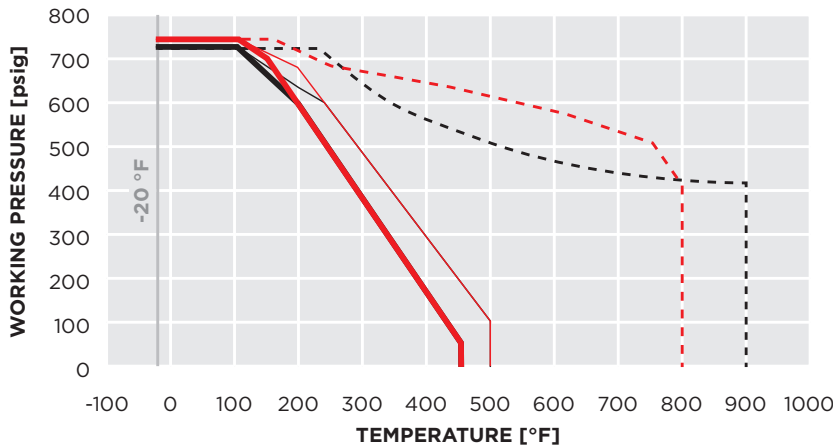

LEGEND (psig/°F)	
	Carbon Steel Body / RPTFE Seat
	Stainless Steel Body / RPTFE Seat
	Carbon Steel Body / PTFE Seat
	Stainless Steel Body / PTFE Seat
	Carbon Steel Body / Inconel Seat
	Stainless Steel Body / Inconel Seat

ASME CLASS 600 — SERIES 44/45
STANDARD / FIRESAFE / METAL SEATED

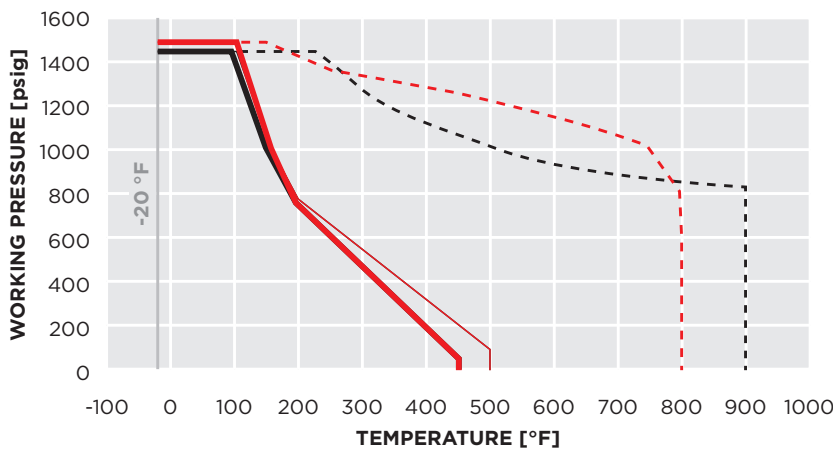

LEGEND (psig/°F)	
	Carbon Steel Body / RPTFE Seat
	Stainless Steel Body / RPTFE Seat
	Carbon Steel Body / PTFE Seat
	Stainless Steel Body / PTFE Seat
	Carbon Steel Body / Inconel Seat
	Stainless Steel Body / Inconel Seat

ASME CLASS 150 — SERIES 40/41/4A
STANDARD / FIRESAFE / METAL SEATED

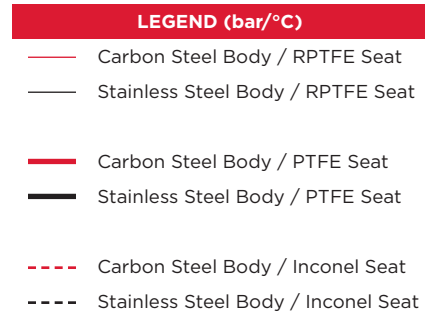
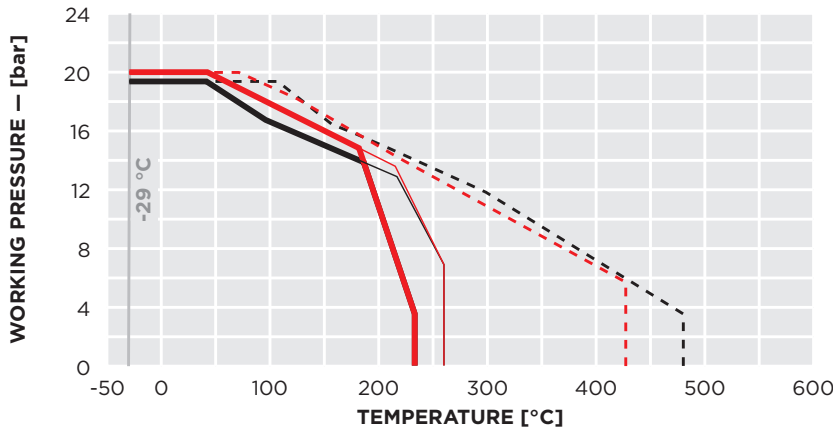

ASME CLASS 300 — SERIES 42/43/4B
STANDARD / FIRESAFE / METAL SEATED

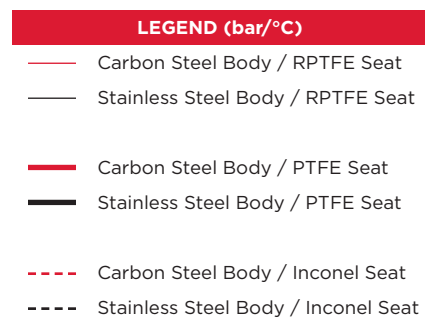
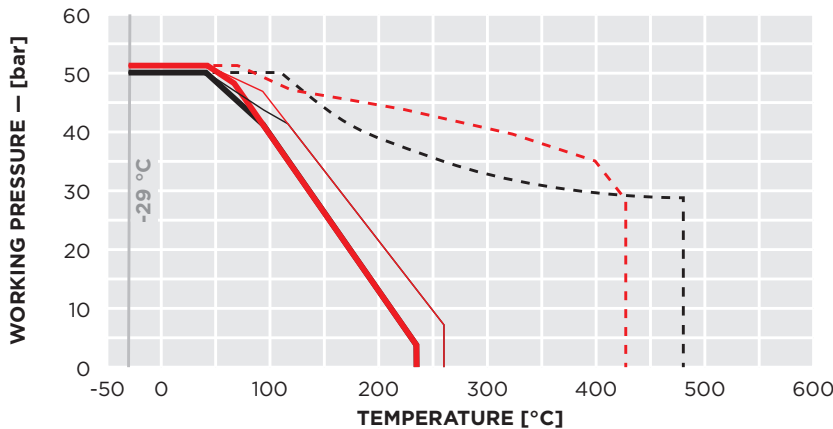

ASME CLASS 600 — SERIES 44/45
STANDARD / FIRESAFE / METAL SEATED

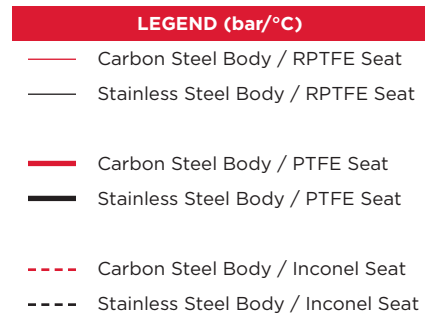
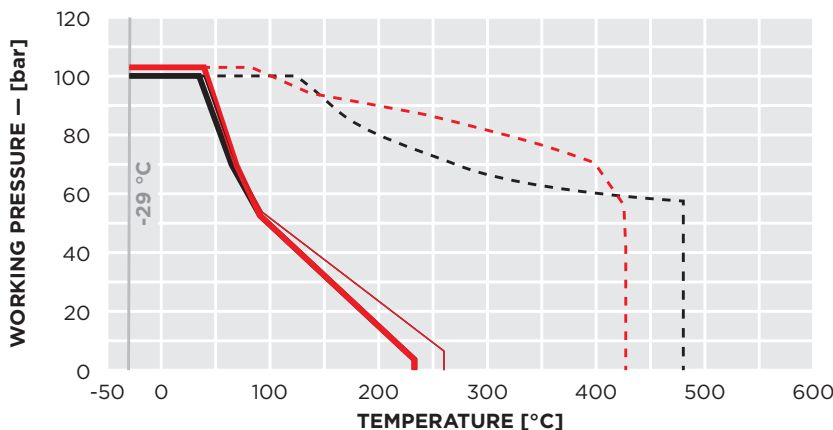

ASME CLASS 150 – SERIES 40 WAFER/41 LUG

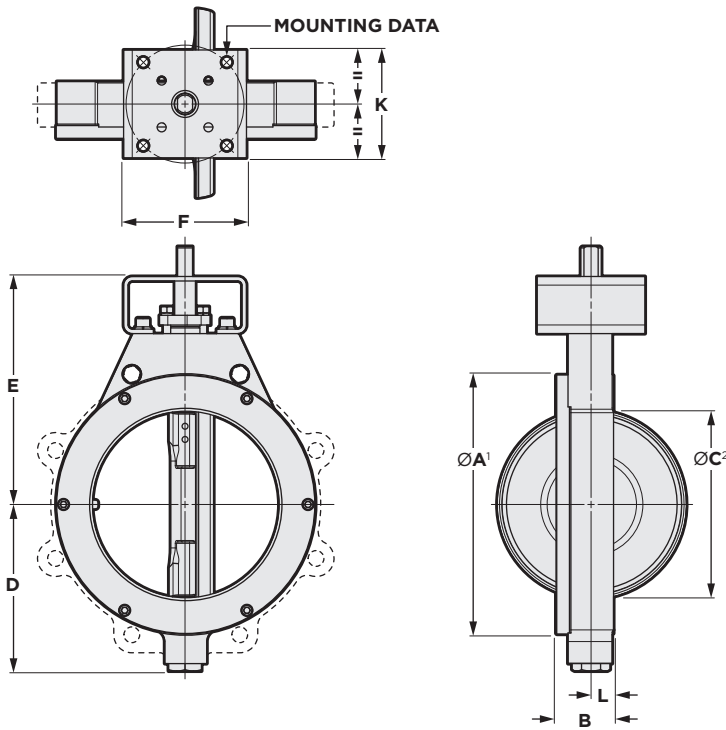

- NOTES**
- > Additional flange drilling options available.
 - > Weights are for cast steel bodies, except when noted.
 - 1 Dimension A is diameter of raised face flange.
 - 2 Dimension C is absolute minimum pipe ID at valve face (without gasket).
 - 3 Flame cut body weights. Flame cut steel and stainless steel bodies vary. Consult Bray factory.

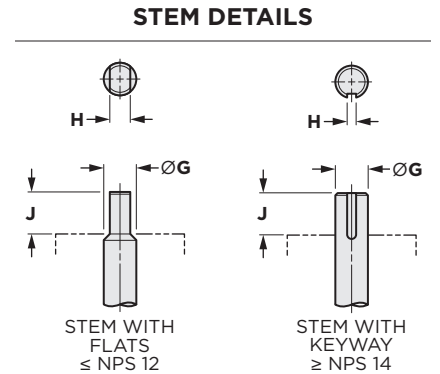

NPS	DIMENSIONS (inches)											WEIGHT (lbs)				
	ØA ¹	B	ØC ²	D	E	F	ØG	H	J	K	L	Mounting Data			Wafer	Lug
												Bolt Circle	Hole Qty	Hole Dia		
2	4.00	1.75	1.94	3.63	6.00	4.36	0.55	0.39	1.25	2.50	0.73	2.76	4	0.38	9	11
2 1/2	4.75	1.88	2.32	3.82	6.38	4.36	0.63	0.43	1.25	2.50	0.77	2.76	4	0.38	11	13
3	5.25	1.88	2.90	4.10	6.63	4.36	0.63	0.43	1.25	2.50	0.77	2.76	4	0.38	13	15
4	6.72	2.03	3.83	4.72	7.50	4.36	0.63	0.43	1.25	2.50	0.75	2.76	4	0.38	20	23
5	7.62	2.23	4.81	5.07	7.50	5.12	0.75	0.51	1.25	4.50	0.94	4.92	4	0.53	27	32
6	8.62	2.23	5.88	5.57	8.00	5.12	0.75	0.51	1.25	4.50	0.94	4.92	4	0.53	32	36
8	10.81	2.40	7.94	6.94	9.50	5.12	0.88	0.63	1.25	4.50	0.94	4.92	4	0.53	48	54
10	13.06	2.75	10.02	8.56	10.75	6.12	1.18	0.87	2.00	4.50	1.07	4.92	4	0.53	79	93
12	15.42	3.08	11.87	10.18	12.25	6.12	1.18	0.87	2.00	4.50	1.13	4.92	4	0.53	118	134
14	17.24	3.73	13.00	11.95	14.50	7.75	1.38	.39 x .39	2.00	6.50	1.42	4.92	4	0.53	211	221
16	19.50	4.11	14.75	13.10	11.75	10.38	1.97	.47 x .39	2.50	6.50	1.66	6.50	4	0.81	314	337
18	21.38	4.61	16.62	14.37	20.00	10.38	1.97	.47 x .39	2.50	6.50	1.86	6.50	4	0.81	404	429
20	23.62	5.03	18.50	15.55	22.75	10.38	2.50	.63 x .63	4.00	6.50	2.06	6.50	4	0.81	533	568
24	27.96	6.00	22.62	18.38	25.00	15.38	3.00	.75 x .75	4.00	11.75	2.44	10.00	8	0.67	810	849
26	29.50	6.50	24.00	19.23	25.00	15.38	3.00	.75 x .75	4.00	11.75	2.84	10.00	8	0.67	1053 ³	1208 ³
28	32.41	6.50	26.62	20.55	26.75	15.38	3.00	.75 x .75	4.00	11.75	2.81	10.00	8	0.67	1119	1228
30	34.41	7.50	28.25	21.38	28.75	19.50	3.50	.88 x .63	5.25	13.50	3.10	11.73	8	0.81	1466	1577
32	37.62	7.50	30.25	22.36	30.00	19.50	3.50	.88 x .63	5.25	13.50	3.22	11.73	8	0.81	1650 ³	1825 ³
34	39.62	7.75	31.50	23.86	30.00	19.50	3.50	.88 x .63	5.25	13.50	3.35	11.73	8	0.81	1890 ³	2340 ³
36	39.87	8.26	34.00	25.27	33.00	19.50	3.50	.88 x .63	5.25	13.50	3.63	11.73	8	0.81	1983	2294
40	44.20	9.51	37.50	27.25	37.00	19.50	4.50	1.0 x .75	5.25	13.50	4.38	11.73	8	0.81	2625 ³	3515 ³
42	46.20	9.51	39.50	29.37	38.00	19.50	4.50	1.0 x .75	5.25	13.50	4.38	11.73	8	0.81	3216 ³	3813
48	52.25	10.00	46.00	33.12	42.13	24.00	5.00	1.25 x .88	6.00	16.00	4.50	14.02	8	1.25	4582 ³	5119 ³
54	58.88	10.75	52.45	35.68	45.50	24.00	6.00	1.5 x 1.0	6.50	16.00	4.75	14.02	8	1.25	5172 ³	6618 ³
60	64.63	12.50	58.50	38.94	50.75	26.00	7.00	1.75 x 1.5	7.50	18.70	5.50	15.98	8	1.50	7168 ³	7793
66	72.75	12.00	64.75	42.69	50.31	23.00	4.50	1.0 x .75	5.25	16.00	5.93	14.02	8	1.25	—	6947

ASME CLASS 150 — SERIES 4A DOUBLE FLANGED

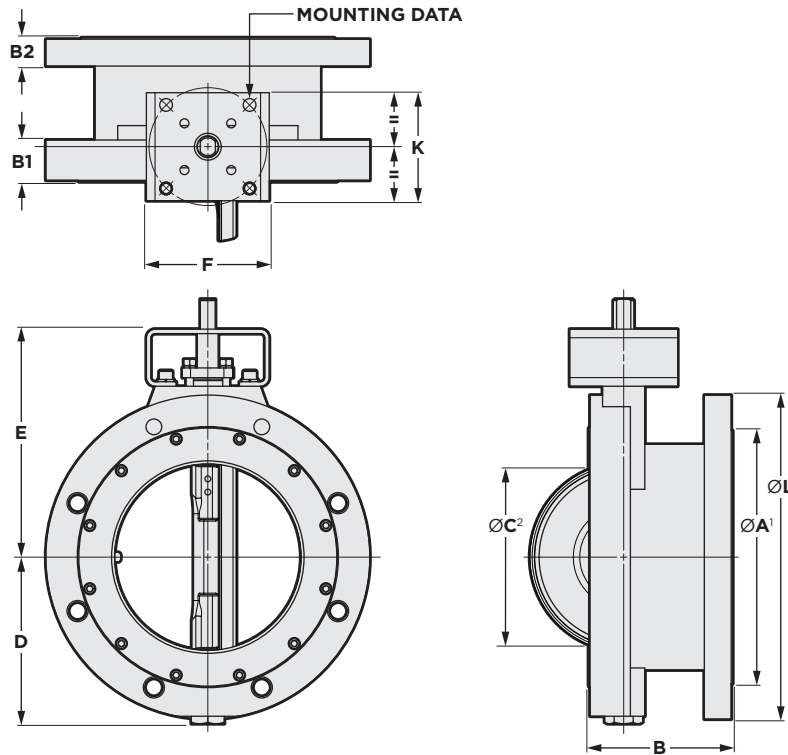

NOTES
 > Additional flange drilling options available.
 1 Dimension A is diameter of raised face flange.
 2 Dimension C is absolute minimum pipe ID at valve face (without gasket).

STEM DETAILS

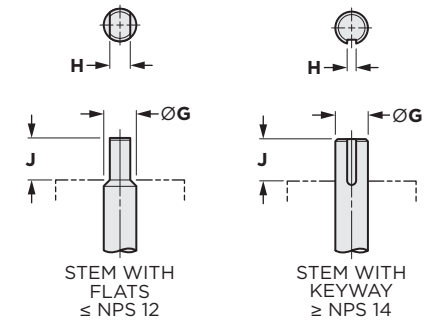

NPS	DIMENSIONS (inches)														WEIGHT (lbs)		
	ØA¹	B	B1	B2	ØC²	D	E	F	ØG	H	J	K	L	Mounting Data			
	Bolt Circle	Hole Qty	Hole Dia														
3	5.25	4.50	1.40	1.06	2.30	4.10	6.63	4.36	0.63	0.43	1.25	2.50	7.50	2.76	4	0.38	31
4	6.75	5.00	1.47	1.06	3.15	4.74	7.50	4.36	0.63	0.43	1.25	2.50	9.00	2.76	4	0.38	45
5	7.42	5.50	1.36	1.06	4.56	5.09	7.50	5.12	0.75	0.51	1.25	4.50	10.00	2.76	4	0.38	58
6	8.63	5.50	1.51	1.06	5.63	5.50	8.00	5.12	0.75	0.51	1.25	4.50	11.00	2.76	4	0.38	64
8	10.62	6.00	1.74	1.18	7.63	6.94	9.50	5.12	0.88	0.63	1.25	4.50	13.50	4.92	4	0.53	103
10	13.09	6.50	1.81	1.25	9.56	8.56	10.75	6.12	1.18	0.87	2.00	4.50	16.00	4.92	4	0.53	152
12	15.49	7.00	2.07	1.31	11.37	10.18	12.25	6.12	1.18	0.87	2.00	4.50	19.00	4.92	4	0.53	228
14	17.25	7.50	2.28	1.44	12.50	11.95	14.50	7.75	1.38	.39 x .39	2.00	6.50	21.00	4.92	4	0.53	359
16	19.75	8.50	2.24	1.50	14.25	13.10	17.75	10.38	1.97	.47 x .39	2.50	6.50	23.50	6.50	4	0.81	481
18	21.38	8.75	2.45	1.62	16.25	14.37	20.00	10.38	1.97	.47 x .39	2.50	6.50	25.00	6.50	4	0.81	585
20	23.62	8.99	2.58	1.74	18.12	15.55	22.75	10.38	2.50	.63 x .63	4.00	6.50	28.15	6.50	4	0.81	774
24	27.96	10.56	3.00	1.94	22.00	18.38	25.00	15.38	3.00	.75 x .75	4.00	11.75	33.00	10.00	8	0.67	1179
28	32.00	11.50	4.00	2.88	26.12	20.55	26.75	15.38	3.00	.75 x .75	4.00	11.75	36.50	10.00	8	0.67	1680
30	34.50	12.52	4.33	3.07	27.75	21.36	28.75	19.50	3.50	.88 x .63	5.25	13.50	38.75	11.73	8	0.81	1266
32	36.00	12.54	4.90	3.32	29.75	22.36	30.00	19.50	3.50	.88 x .63	5.25	13.50	41.75	11.73	8	0.81	2408
36	40.25	12.99	5.57	3.69	33.50	25.27	33.00	19.50	3.50	.88 x .63	5.25	13.50	46.00	11.73	8	0.81	3061
42	48.00	16.14	5.82	3.94	39.50	29.37	38.00	19.50	4.50	1.0 x .75	5.25	13.50	53.31	11.73	8	0.81	5005

NOTE
 > For sizes not shown, contact Bray for more information.

ASME CLASS 300 – SERIES 42 WAFER/43 LUG

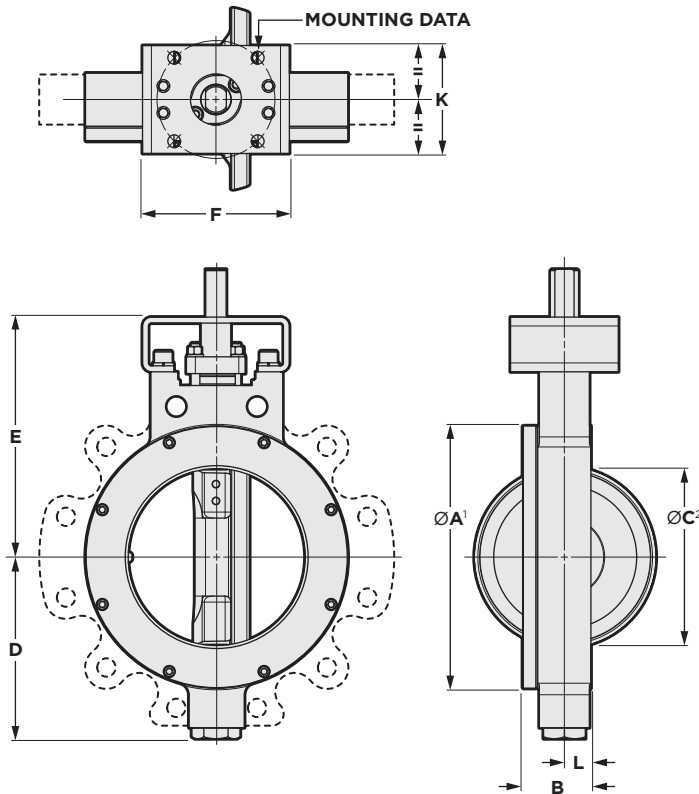

NOTES

- > Additional flange drilling options available.
- > Weights are for cast steel bodies, except when noted.
- 1 Dimension A is diameter of raised face flange.
- 2 Dimension C is absolute minimum pipe ID at valve face (without gasket).

STEM DETAILS

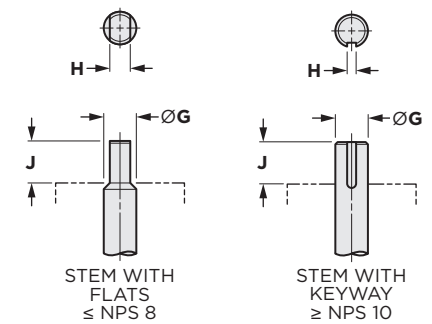

NPS	DIMENSIONS (inches)											WEIGHT (lbs)				
	ØA ¹	B	ØC ²	D	E	F	ØG	H	J	K	L	Mounting Data			Wafer	Lug
												Bolt Circle	Hole Qty	Hole Dia		
2	4.00	1.75	1.94	3.63	6.00	4.36	0.55	0.39	1.25	2.50	0.73	2.76	4	0.38	9	11
2 1/2	4.75	1.88	2.32	3.82	6.38	4.36	0.63	0.43	1.25	2.50	0.77	2.76	4	0.38	11	13
3	5.25	1.88	2.90	4.10	6.63	4.36	0.63	0.43	1.25	2.50	0.77	2.76	4	0.38	13	15
4	6.72	2.03	3.83	4.72	7.50	4.36	0.63	0.43	1.25	2.50	0.75	2.76	4	0.38	20	23
5	8.25	2.23	4.81	5.07	8.00	5.12	0.75	0.51	1.25	4.50	0.94	4.92	4	0.53	33	39
6	8.88	2.42	5.76	6.25	8.75	5.12	0.87	0.63	1.25	4.50	0.99	4.92	4	0.53	41	51
8	10.94	2.82	7.63	7.55	10.00	6.12	1.18	0.87	2.00	4.50	1.10	4.92	4	0.53	69	83
10	13.26	3.28	9.50	9.36	11.38	6.12	1.38	.39 x .39	2.00	4.50	1.28	4.92	4	0.53	114	137
12	15.42	3.62	11.37	10.89	13.50	7.75	1.38	.39 x .39	2.00	6.50	1.40	4.92	4	0.53	173	210
14	17.27	4.66	11.50	12.50	18.25	10.38	1.97	.47 x .39	2.50	6.50	2.13	6.50	4	0.81	333	445
16	19.50	5.35	14.38	14.18	21.00	10.38	2.50	.63 x .63	4.00	6.50	2.50	6.50	4	0.81	454	531
18	21.38	5.98	15.25	15.43	21.00	15.38	2.50	.63 x .63	4.00	11.75	2.65	10.00	8	0.67	609	753
20	23.76	6.33	16.50	16.80	22.25	15.38	3.00	.75 x .75	4.00	11.75	2.90	10.00	8	0.67	783	960
24	28.75	7.15	20.88	19.80	26.25	19.50	3.50	.88 x .63	5.25	13.50	3.40	11.73	8	0.81	1281	1555
30	35.00	9.00	27.50	23.40	32.25	24.00	4.50	1.0 x .75	5.25	16.00	4.31	14.02	8	1.25	2247	2738
36	42.06	10.67	33.50	27.12	36.25	24.00	5.00	1.25 x .88	6.00	16.00	5.23	14.02	8	1.12	3203	3992
42	45.63	11.51	39.50	29.25	40.50	26.00	6.00	1.5 x 1.0	6.50	18.70	5.13	15.98	8	1.25	4417	4694
48	52.06	12.50	45.75	33.16	44.75	29.00	7.00	1.75 x 1.50	7.50	22.00	5.50	19.02	12	1.50	6210	6600

NOTE

> For sizes not shown, contact Bray for more information.

ASME CLASS 300 – SERIES 4B DOUBLE FLANGED

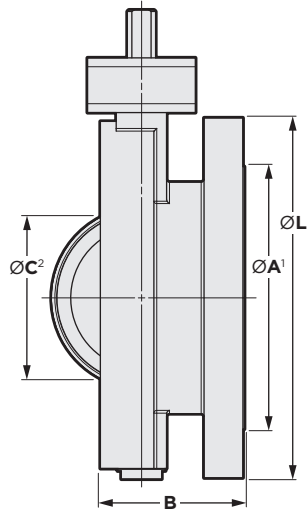
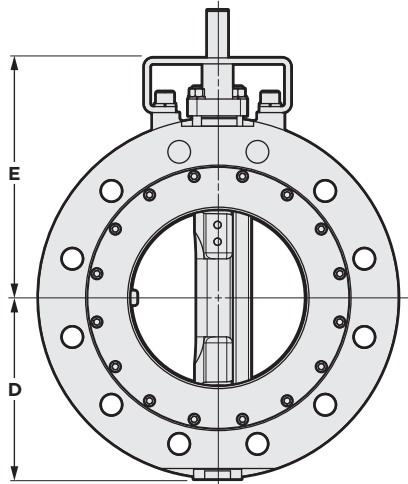
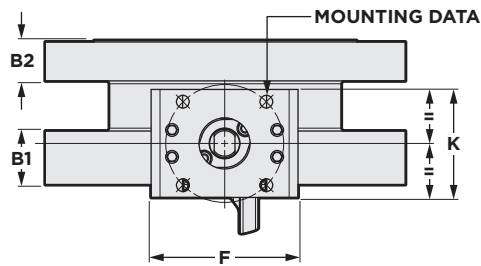

NOTES

- > Additional flange drilling options available.
- > Weights are for cast steel bodies, except when noted.
- 1 Dimension A is diameter of raised face flange.
- 2 Dimension C is absolute minimum pipe ID at valve face (without gasket).

STEM DETAILS

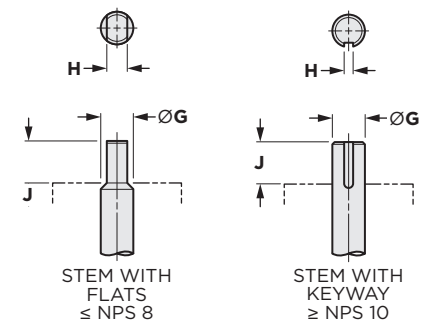

NPS	DIMENSIONS (inches)													WEIGHT (lbs)			
	ØA¹	B	B1	B2	ØC²	D	E	F	ØG	H	J	K	L	Mounting Data			
														Bolt Circle	Hole Qty	Hole Dia	
3	5.25	4.49	1.57	1.12	2.62	4.10	6.63	4.36	0.63	0.43	1.25	2.50	8.25	2.76	4	0.38	39
4	7.00	5.00	1.78	1.25	3.15	4.72	7.50	4.36	0.63	0.43	1.25	2.50	10.00	2.76	4	0.38	62
6	8.50	5.50	1.97	1.44	5.38	6.25	8.75	5.12	0.87	0.63	1.25	4.50	12.50	4.92	4	0.53	86
8	10.94	6.00	2.23	1.68	7.00	7.55	10.00	6.12	1.18	0.87	2.00	4.50	15.00	4.92	4	0.53	171
10	12.78	6.50	2.60	1.94	8.87	9.36	11.38	6.12	1.38	.39 x .39	2.00	4.50	17.50	4.92	4	0.53	209
12	15.00	7.00	2.81	2.06	10.87	10.89	13.50	7.75	1.38	.39 x .39	2.00	6.50	20.50	4.92	4	0.53	401
14	16.25	7.50	2.99	2.18	11.19	12.50	18.25	10.38	1.97	.47 x .39	2.50	6.50	23.00	6.50	4	0.81	613
16	17.80	8.50	3.19	2.31	14.12	14.18	21.00	10.38	2.50	.63 x .63	4.00	6.50	25.50	6.50	4	0.81	773
18	21.00	8.75	3.69	2.44	14.44	15.43	21.00	15.38	2.50	.63 x .63	4.00	11.75	28.00	10.00	8	0.67	1046
20	23.00	9.00	3.63	2.56	16.50	16.80	22.25	15.38	3.00	.75 x .75	4.00	11.75	30.50	10.00	8	0.67	1290
24	27.25	10.50	4.00	2.81	20.38	19.80	26.25	19.50	3.50	.88 x .63	5.25	13.50	36.00	11.73	8	0.81	2011
30	33.81	12.52	5.12	3.71	27.50	23.40	32.25	24.00	4.50	1.0 x .75	5.25	16.00	43.00	14.02	8	1.25	2339
36	40.26	12.99	6.15	4.21	33.50	27.12	36.25	24.00	5.00	1.25 x .88	6.00	16.00	50.00	14.02	8	1.25	4636
42	45.63	16.14	7.07	4.82	39.50	29.25	40.50	26.00	6.00	1.5 x 1.0	6.50	18.70	50.75	15.98	8	1.25	5475

NOTE

> For sizes not shown, contact Bray for more information.

ASME CLASS 600 – SERIES 44 WAFER/45 LUG

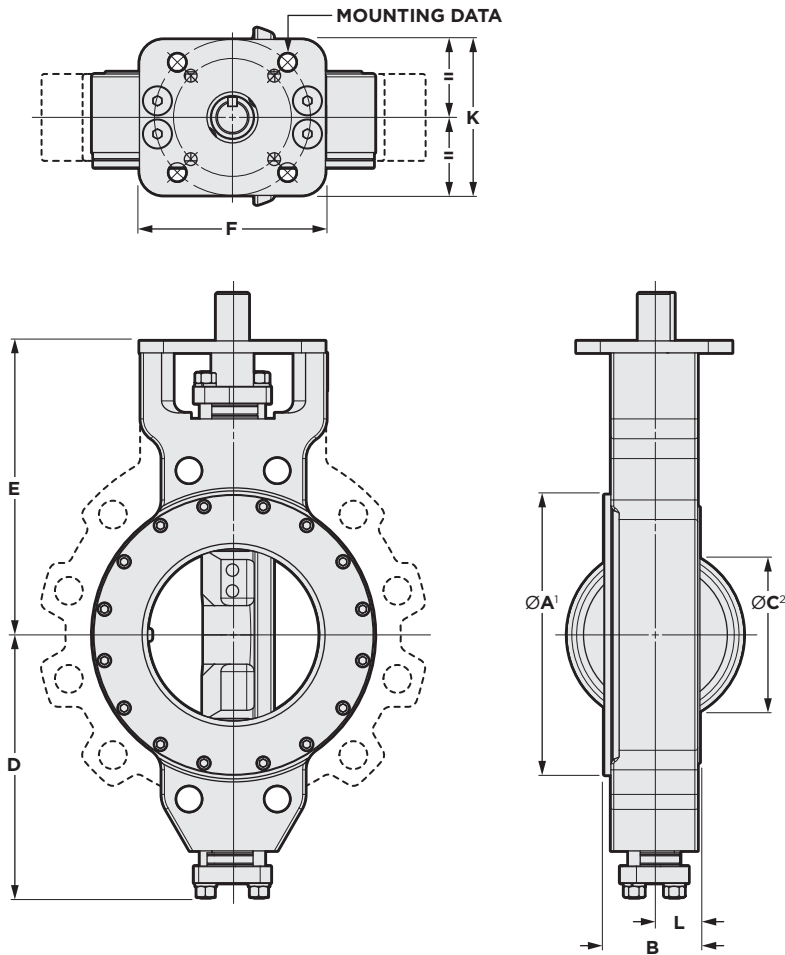

NOTES

- > Additional flange drilling options available.
- > Weights are for cast steel bodies, except when noted.
- 1 Dimension A is diameter of raised face flange.
- 2 Dimension C is absolute minimum pipe ID at valve face (without gasket).
- 3 Flame cut body weights. Flame cut steel and stainless steel bodies vary. Consult Bray factory.

STEM DETAILS

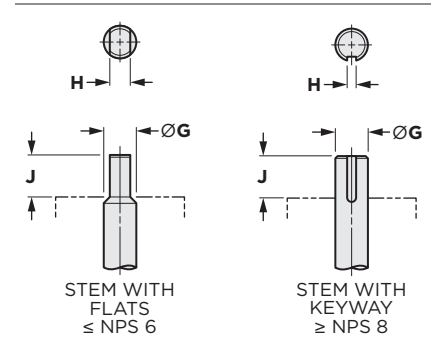

DIMENSIONS (inches)												WEIGHT (lbs)				
NPS	ØA ¹	B	ØC ²	D	E	F	ØG	H	J	K	L	Mounting Data			Wafer	Lug
												Bolt Circle	Hole Qty	Hole Dia.		
3	5.69	2.22	2.90	5.79	7.00	5.12	0.75	0.51	1.19	4.50	0.90	2.76	4	0.38	25 ³	30 ³
4	7.00	2.77	3.62	7.10	8.50	5.12	1.00	0.63	1.19	4.50	1.15	4.92	4	0.53	40 ³	48 ³
6	9.62	3.34	5.19	8.57	9.75	6.12	1.18	0.87	2.00	4.50	1.38	4.92	4	0.53	78 ³	106 ³
8	11.69	4.23	7.00	10.95	12.25	7.75	0.69	.39 x .39	2.00	6.50	1.90	6.50	4	0.81	149 ³	203 ³
10	13.75	4.82	8.75	14.66	17.00	10.38	1.97	.47 x .39	2.50	6.50	1.96	6.50	4	0.81	281 ³	367 ³
12	16.12	5.51	10.50	15.72	18.25	10.38	1.97	.47 x .39	2.50	6.50	2.53	6.50	4	0.81	407 ³	552 ³
14	17.63	6.09	11.19	17.79	19.75	15.38	2.50	.62 x .62	4.00	11.75	2.90	10.00	8	0.67	497 ³	704 ³
16	20.38	7.00	12.81	19.67	21.75	15.38	3.00	.75 x .75	4.00	11.75	3.44	10.00	8	0.67	681 ³	997 ³
18	22.88	7.75	14.88	21.05	23.75	19.50	3.50	.88 x .62	5.25	13.50	3.60	11.73	8	0.81	992 ³	1311 ³
20	24.63	8.50	16.50	23.21	25.75	19.50	4.00	1 x .75	5.25	13.50	3.88	11.73	8	0.81	1360 ³	1850 ³
24	29.19	9.13	19.88	27.88	31.00	24.00	5.00	1.25 x .88	6.00	16.00	3.94	14.02	8	1.25	1945 ³	2612 ³
36	40.25	13.97	33.50	38.75	44.54	33.50	7.00	1.75 x 1.25	6.75	22.00	5.78	19.01	12	1.50	5274 ³	7095 ³

NOTE

> For sizes not shown, contact Bray for more information.

ASME CLASS 150 – SERIES 40 WAFER/41 LUG

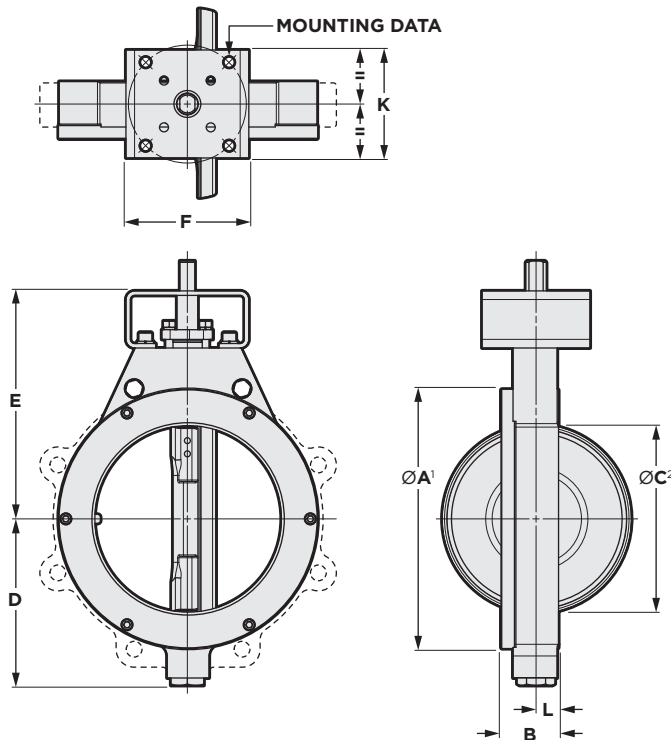

NOTES

- > Additional flange drilling options available.
 - > Weights are for cast steel bodies, except when noted.
 - > Metric dimensions are converted from imperial.
- 1 Dimension A is diameter of raised face flange.
 2 Dimension C is absolute minimum pipe ID at valve face (without gasket).
 3 Flame cut body weights. Flame cut steel and stainless steel bodies vary. Consult Bray factory.

STEM DETAILS

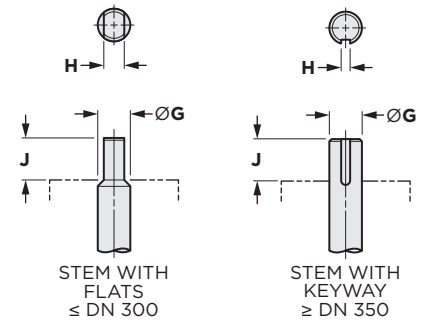

DIMENSIONS (millimeters)												WEIGHT (kg)				
DN	ØA ¹	B	ØC ²	D	E	F	ØG	H	J	K	L	Mounting Data			Wafer	Lug
												Bolt Hole Qty	Hole Dia			
50	102	44	49	92	152	111	14	10	32	64	19	70	4	10	4	5
65	121	48	59	97	162	111	16	11	32	64	19	70	4	10	5	6
80	133	48	74	104	168	111	16	11	32	64	19	70	4	10	6	7
100	171	52	97	120	191	111	16	11	32	64	19	70	4	10	9	10
125	194	57	122	129	191	130	19	13	32	114	24	125	4	13	12	14
150	219	57	149	142	203	130	19	13	32	114	24	125	4	13	15	16
200	275	61	202	176	241	130	22	16	32	114	24	125	4	13	22	24
250	332	70	255	217	273	155	30	22	51	114	27	125	4	13	36	42
300	392	78	302	259	311	155	30	22	51	114	29	125	4	13	54	61
350	438	95	330	304	368	197	35	10 x 10	51	165	36	125	4	13	96	100
400	495	104	375	333	298	264	50	12 x 10	64	165	42	165	4	21	142	153
450	543	117	422	365	508	264	50	12 x 10	64	165	47	165	4	21	183	194
500	600	128	470	395	578	264	64	16 x 16	102	165	52	165	4	21	242	258
600	710	152	575	467	635	391	76	19 x 19	102	298	62	254	8	17	368	385
650	749	165	610	489	635	391	76	19 x 19	102	298	72	254	8	17	477 ³	548 ³
700	823	165	676	522	679	391	76	19 x 19	102	298	71	254	8	17	508	557
750	874	191	718	543	730	495	89	22 x 16	133	343	79	298	8	21	665	715
800	956	191	768	568	762	495	89	22 x 16	133	343	82	298	8	21	748 ³	828 ³
850	1006	197	800	606	762	495	89	22 x 16	133	343	85	298	8	21	857 ³	1061 ³
900	1013	210	864	642	838	495	89	22 x 16	133	343	92	298	8	21	899	1041
1000	1123	241	953	692	940	495	114	25 x 19	133	343	111	298	8	21	1191 ³	1594 ³
1050	1173	241	1003	746	965	495	114	25 x 19	133	343	111	298	8	21	1459 ³	1729
1200	1327	254	1168	841	1070	610	127	32 x 22	152	406	114	356	8	32	2079 ³	2322 ³
1400	1496	273	1332	906	1156	610	152	38 x 25	165	406	121	356	8	32	2346 ³	3002
1500	1642	318	1486	989	1289	660	178	44 x 38	191	475	140	406	8	38	3251 ³	3535 ³
1650	1848	305	1645	1084	1278	584	114	25 x 19	133	406	151	356	8	32	—	3151

ASME CLASS 150 – SERIES 4A DOUBLE FLANGED

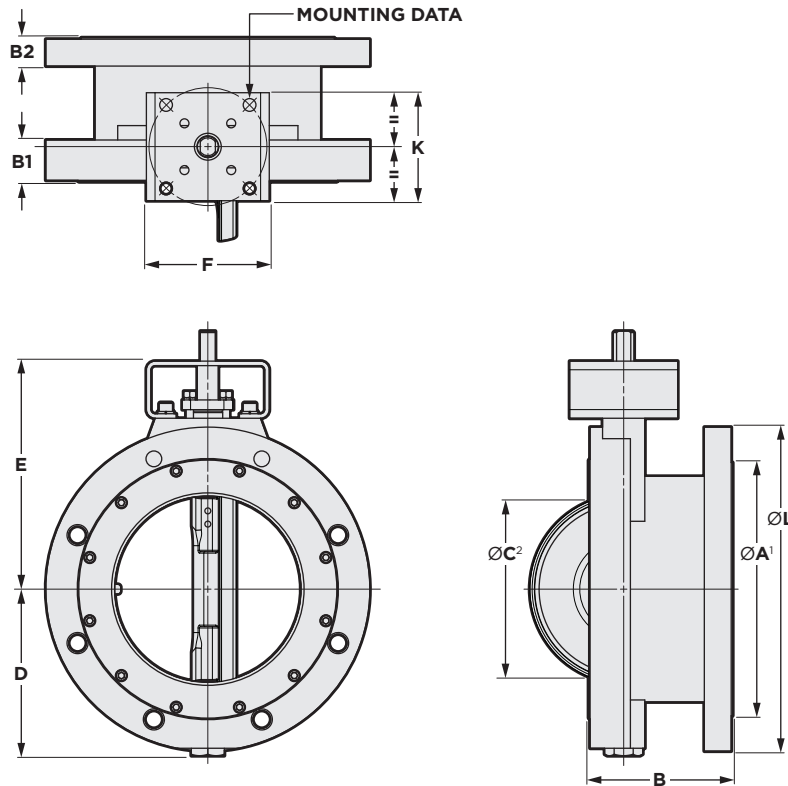

- NOTES**
- > Additional flange drilling options available.
 - > Weights are for cast steel bodies, except when noted.
 - > Metric dimensions are converted from imperial.
- 1 Dimension A is diameter of raised face flange.
 2 Dimension C is absolute minimum pipe ID at valve face (without gasket).

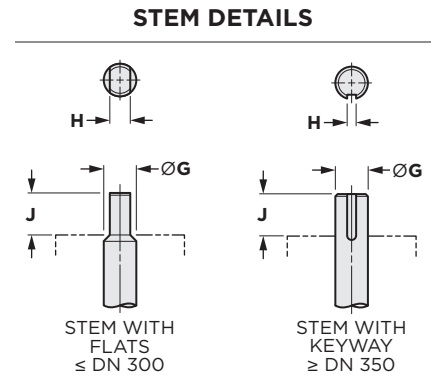

DIMENSIONS (millimeters)														WEIGHT (kg)			
DN	ØA ¹	B	B1	B2	ØC ²	D	E	F	ØG	H	J	K	L	Mounting Data			
														Bolt Circle	Hole Qty	Hole Dia	
80	133	114	36	27	58	104	168	111	16	11	32	64	191	70	4	10	14
100	171	127	37	27	80	120	191	111	16	11	32	64	229	70	4	10	21
125	189	140	35	27	116	129	191	130	19	13	32	114	254	70	4	10	26
150	219	140	38	27	143	140	203	130	19	13	32	114	279	70	4	10	29
200	270	152	44	30	194	176	241	130	22	16	32	114	343	125	4	13	47
250	333	165	46	32	243	217	273	155	30	22	51	114	406	125	4	13	69
300	393	178	53	33	289	259	311	155	30	22	51	114	483	125	4	13	103
350	438	191	58	37	318	304	368	197	35	10 x 10	51	165	533	125	4	13	163
400	502	216	57	38	362	333	451	264	50	12 x 10	64	165	597	165	4	21	218
450	543	222	62	41	413	365	508	264	50	12 x 10	64	165	635	165	4	21	265
500	600	228	66	44	460	395	578	264	64	16 x 16	102	165	715	165	4	21	351
600	710	268	76	49	559	467	635	391	76	19 x 19	102	298	838	254	8	17	535
700	813	292	101	73	664	522	679	391	76	19 x 19	102	298	927	254	8	17	762
750	876	318	110	78	705	542	730	495	89	22 x 16	133	343	984	298	8	21	574
800	914	318	125	84	756	568	762	495	89	22 x 16	133	343	1060	298	8	21	1092
900	1022	330	141	94	851	642	838	495	89	22 x 16	133	343	1168	298	8	21	1388
1050	1219	410	148	100	1003	746	965	495	114	25 x 19	133	343	1354	298	8	21	2270

NOTE
 > For sizes not shown, contact Bray for more information.

ASME CLASS 300 – SERIES 42 WAFER/43 LUG

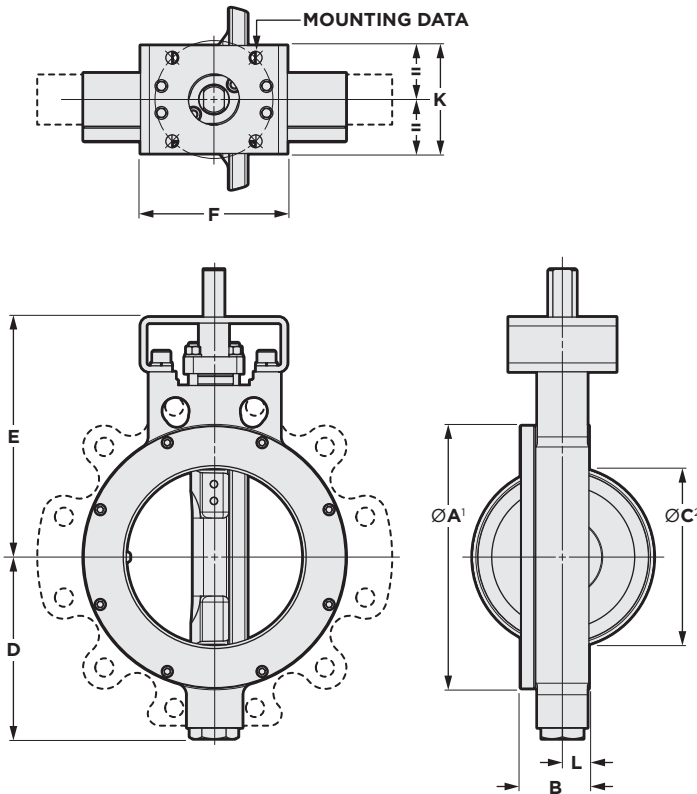

NOTES

- > Additional flange drilling options available.
 - > Weights are for cast steel bodies, except when noted.
 - > Metric dimensions are converted from imperial.
- 1 Dimension A is diameter of raised face flange.
 2 Dimension C is absolute minimum pipe ID at valve face (without gasket).

STEM DETAILS

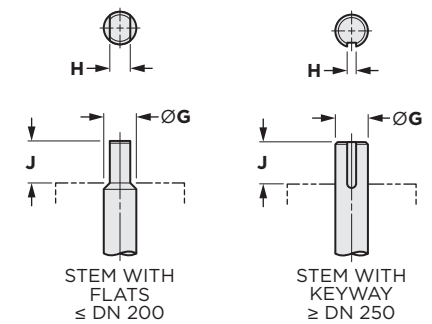

DIMENSIONS (millimeters)												WEIGHT (kg)				
DN	ØA ¹	B	ØC ²	D	E	F	ØG	H	J	K	L	Mounting Data				
												Bolt Qty	Hole Dia	Hole Dia	Wafer	Lug
50	102	44	49	92	152	111	14	10	32	64	19	70	4	10	4	5
65	121	48	59	97	162	111	16	11	32	64	19	70	4	10	5	6
80	133	48	74	104	168	111	16	11	32	64	19	70	4	10	6	7
100	171	52	97	120	191	111	16	11	32	64	19	70	4	10	9	10
125	210	57	122	129	203	130	19	13	32	114	24	125	4	13	15	17
150	226	61	146	159	222	130	22	16	32	114	25	125	4	13	18	23
200	278	72	194	192	254	155	30	22	51	114	28	125	4	13	31	38
250	337	83	241	238	289	155	35	10 x 10	51	114	33	125	4	13	52	62
300	392	92	289	277	343	197	35	10 x 10	51	165	36	125	4	13	78	95
350	439	118	292	318	464	264	50	12 x 10	64	165	54	165	4	21	151	202
400	495	136	365	360	533	264	64	16 x 16	102	165	64	165	4	21	206	241
450	543	152	387	392	533	391	64	16 x 16	102	298	67	254	8	17	276	342
500	604	161	419	427	565	391	76	19 x 19	102	298	74	254	8	17	355	436
600	730	181	530	503	667	495	89	22 x 16	133	343	86	298	8	21	581	705
750	889	229	699	594	819	610	114	25 x 19	133	406	109	356	8	32	1019	1242
900	1068	271	851	689	921	610	127	32 x 22	152	406	133	356	8	28	1453	1811
1050	1159	292	1003	743	1029	660	152	38 x 25	165	475	130	406	8	32	2003	2129
1200	1322	318	1162	842	1137	737	178	44 x 38	191	559	140	483	12	38	2817	2994

NOTE

> For sizes not shown, contact Bray for more information.

ASME CLASS 300 – SERIES 4B DOUBLE FLANGED

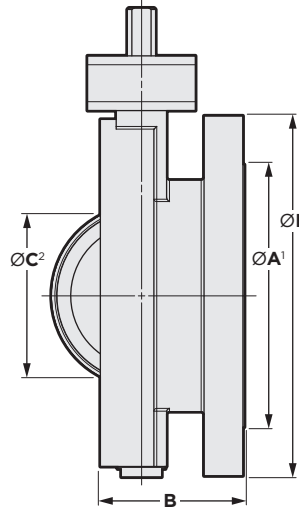
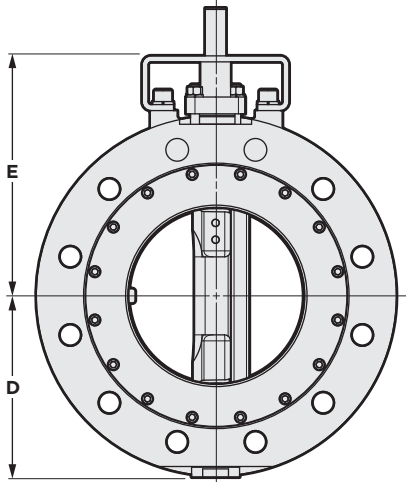
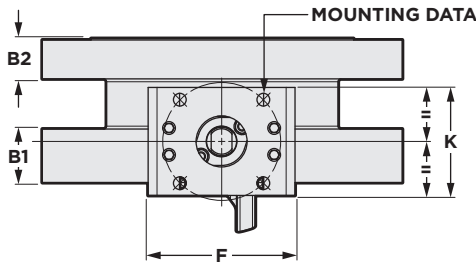

NOTES

- > Additional flange drilling options available.
 - > Weights are for cast steel bodies, except when noted.
 - > Metric dimensions are converted from imperial.
- 1 Dimension A is diameter of raised face flange.
 2 Dimension C is absolute minimum pipe ID at valve face (without gasket).

STEM DETAILS

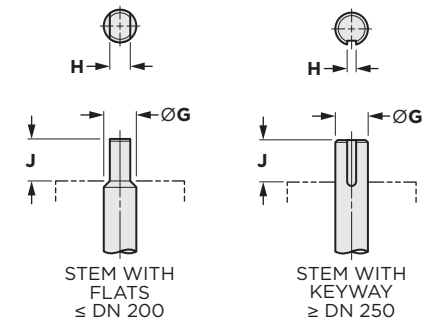

DIMENSIONS (millimeters)														WEIGHT (kg)			
DN	ØA ¹	B	B1	B2	ØC ²	D	E	F	ØG	H	J	K	L	Mounting Data			
														Bolt Circle	Hole Qty	Hole Dia	
80	133	114	40	28	67	104	168	111	16	11	32	64	210	70	4	10	18
100	178	127	45	32	80	120	191	111	16	11	32	64	254	70	4	10	28
150	216	140	50	37	137	159	222	130	22	16	32	114	318	125	4	13	39
200	278	152	57	43	178	192	254	155	30	22	51	114	381	125	4	13	78
250	325	165	66	49	225	238	289	155	35	10 x 10	51	114	445	125	4	13	95
300	381	178	71	52	276	277	343	197	35	10 x 10	51	165	521	125	4	13	182
350	413	191	76	55	284	318	464	264	50	12 x 10	64	165	584	165	4	21	278
400	452	216	81	59	359	360	533	264	64	16 x 16	102	165	648	165	4	21	350
450	533	222	94	62	367	392	533	391	64	16 x 16	102	298	711	254	8	17	474
500	584	229	92	65	419	427	565	391	76	19 x 19	102	298	775	254	8	17	585
600	692	267	102	71	518	503	667	495	89	22 x 16	133	343	914	298	8	21	912
750	859	318	130	94	699	594	819	610	114	25 x 19	133	406	1092	356	8	32	1061
900	1023	330	156	107	851	689	921	610	127	32 x 22	152	406	1270	356	8	32	2103
1050	1159	410	180	122	1003	743	1029	660	152	38 x 25	165	475	1289	406	8	32	2483

NOTE

> For sizes not shown, contact Bray for more information.

ASME CLASS 600 – SERIES 44 WAFER/45 LUG

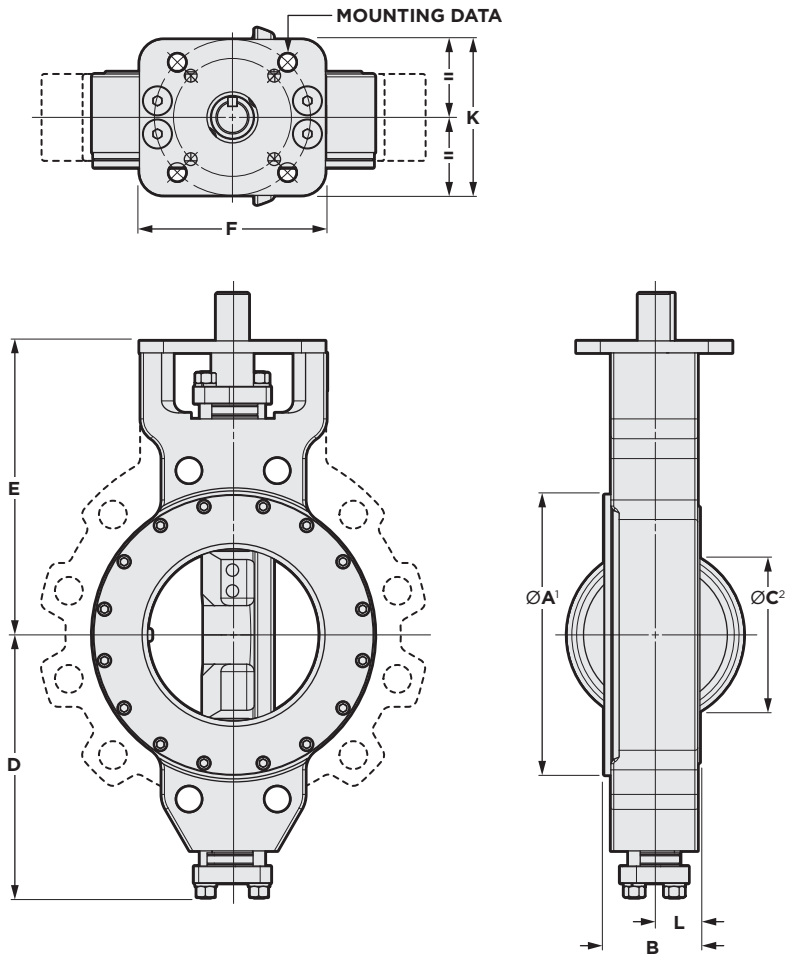

NOTES

- > Additional flange drilling options available.
 - > Weights are for cast steel bodies, except when noted.
 - > Metric dimensions are converted from imperial.
- 1 Dimension A is diameter of raised face flange.
 - 2 Dimension C is absolute minimum pipe ID at valve face (without gasket).
 - 3 Flame cut body weights. Flame cut steel and stainless steel bodies vary. Consult Bray factory.

STEM DETAILS

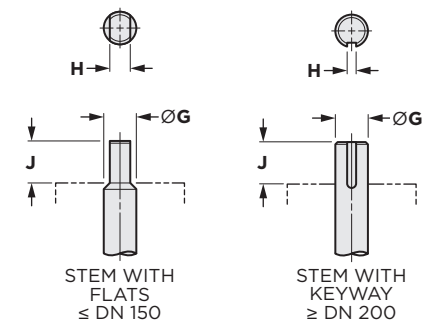

DIMENSIONS (millimeters)												WEIGHT (kg)				
DN	ØA ¹	B	ØC ²	D	E	F	ØG	H	J	K	L	Mounting Data			Wafer	Lug
												Bolt Circle	Hole Qty	Hole Dia		
80	145	56	74	147	178	130	19	13	30	114	23	70	4	10	11 ³	13 ³
100	178	70	92	180	216	130	25	16	30	114	29	125	4	13	18 ³	22 ³
150	244	85	132	218	248	155	30	22	51	114	35	125	4	13	36 ³	48 ³
200	297	107	178	278	311	197	18	10 x 10	51	165	48	165	4	21	68 ³	92 ³
250	349	122	222	372	432	264	50	12 x 10	64	165	50	165	4	21	127 ³	167 ³
300	409	140	267	399	464	264	50	12 x 10	64	165	64	165	4	21	185 ³	250 ³
350	448	155	284	452	502	391	64	16 x 16	102	298	74	254	8	17	226 ³	319 ³
400	518	178	325	500	552	391	76	19 x 19	102	298	87	254	8	17	309 ³	452 ³
450	581	197	378	535	603	495	89	22 x 16	133	343	91	298	8	21	450 ³	595 ³
500	626	216	419	590	654	495	102	25 x 19	133	343	99	298	8	21	617 ³	839 ³
600	741	232	505	708	787	610	127	32 x 22	152	406	100	356	8	32	882 ³	1185 ³
900	1022	355	851	984	1131	851	178	44 x 32	171	559	147	483	12	38	2392 ³	3218 ³

NOTE

> For sizes not shown, contact Bray for more information.

SEAT RETAINER POSITION

NOTE

> Valve orientation to media flow affects torque. Values are presented for upstream and downstream orientations.

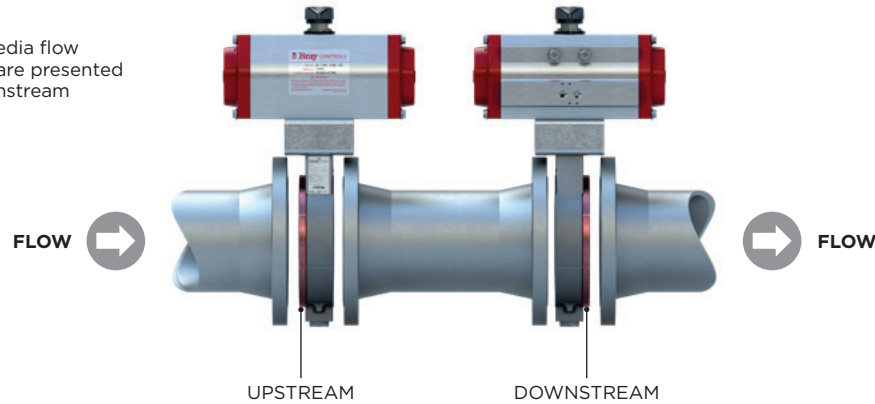

ASME CLASS 150 – SERIES 40/41/4A

STANDARD VALVE – TORQUE VALUES (Lb-in)								
Valve Differential Pressure (psig)								
NPS	<150 psig		>150 to 200 psig		>200 to 250 psig		>250 to 285 psig	
	Seat Retainer		Seat Retainer		Seat Retainer		Seat Retainer	
	Upstream	Downstream	Upstream	Downstream	Upstream	Downstream	Upstream	Downstream
2	155	180	170	220	195	260	200	280
2½	170	200	190	240	210	280	215	300
3	185	220	210	260	225	300	230	320
4	275	320	300	370	315	420	320	460
5	550	650	640	800	705	940	730	1,040
6	690	810	770	960	825	1,100	840	1,200
8	1,280	1,500	1,400	1,700	1,500	1,950	1,570	2,100
10	2,400	2,800	2,640	3,300	2,820	3,760	2,870	4,100
12	3,500	4,100	4,000	5,000	4,400	5,900	4,550	6,500
14	5,400	6,300	5,920	7,400	6,400	8,500	6,650	9,500
16	7,700	9,100	9,040	11,300	10,100	13,500	10,500	15,000
18	11,900	14,000	13,600	17,000	15,000	20,000	15,400	22,000
20	15,300	18,000	17,100	21,300	18,500	24,700	18,900	27,000
24	24,650	29,000	27,680	34,600	30,000	40,100	30,800	44,000
28	34,850	41,000	37,600	47,000	44,300	59,200	44,500	63,500
30	39,950	47,000	42,960	53,700	50,800	67,700	52,500	75,000
32	45,000	53,000	48,800	61,000	57,600	76,800	58,800	84,000
36	54,000	64,000	64,800	81,000	73,500	98,000	77,000	110,000
40	62,000	73,000	73,600	92,000	82,500	110,000	84,700	121,000
42	71,000	83,000	84,000	105,000	95,250	127,000	101,000	143,000
48	98,000	115,000	121,600	152,000	142,500	190,000	151,900	217,000
54	136,000	160,000	169,600	212,000	198,000	265,000	211,400	302,000
60	174,497	211,326	220,929	280,435	262,162	350,544	284,544	399,520

NOTE

> For sizes not shown, contact Bray for more information.

ASME CLASS 150 – SERIES 40/41/4A

FIRESAFE VALVE – TORQUE VALUES (Lb-in)								
Valve Differential Pressure (psig)								
NPS	<150 psig		>150 to 200 psig		>200 to 250 psig		>250 to 285 psig	
	Seat Retainer		Seat Retainer		Seat Retainer		Seat Retainer	
	Upstream	Downstream	Upstream	Downstream	Upstream	Downstream	Upstream	Downstream
2	672	695	680	737	688	769	696	794
2½	680	720	690	770	700	810	710	840
3	750	800	760	830	770	870	780	900
4	850	900	880	980	890	1,050	910	1,100
5	1,420	1,500	1,470	1,630	1,500	1,750	1,600	1,850
6	1,660	1,750	1,690	1,880	1,800	2,000	1,900	2,100
8	2,600	2,800	2,690	2,950	2,750	3,100	2,860	3,200
10	3,900	4,200	4,100	4,530	4,250	4,860	4,400	5,100
12	6,500	6,900	6,600	7,350	6,700	7,790	6,900	8,100
14	12,300	13,000	12,600	14,000	13,200	15,500	13,600	17,000
16	15,200	16,000	15,800	17,600	16,300	19,200	16,320	20,400
18	18,000	19,000	18,900	21,000	19,000	22,500	19,200	24,000
20	21,800	23,000	22,500	25,000	23,800	28,000	28,800	36,000
24	31,000	33,000	34,200	38,000	37,400	44,000	50,400	63,000
28	38,900	42,200	44,900	50,800	50,600	60,900	76,200	102,200
30	46,400	50,200	55,400	62,100	63,800	75,700	97,800	130,100
32	52,500	57,100	64,300	72,400	75,000	89,400	118,200	157,300
36	64,900	76,100	83,300	100,600	99,300	126,900	163,500	227,800
40	75,800	88,600	97,500	117,500	116,500	148,900	235,700	292,800
42	83,200	97,500	10,800	130,400	129,800	166,200	264,400	330,200
48	114,700	135,500	152,900	184,800	186,500	237,900	374,300	475,200

METAL SEATED VALVE – TORQUE VALUES (Lb-in)								
2½	612	648	621	693	630	729	639	756
3	675	720	684	747	693	783	702	810
4	765	810	792	882	801	945	819	990
5	1,278	1,350	1,323	1,467	1,350	1,575	1,440	1,665
6	1,494	1,575	1,521	1,692	1,620	1,800	1,710	1,890
8	2,340	2,520	2,421	2,655	2,475	2,790	2,574	2,880
10	3,510	3,780	3,690	4,077	3,825	4,374	3,960	4,590
12	5,850	6,210	5,940	6,615	6,030	7,011	6,210	7,290
14	11,070	11,700	11,340	12,600	11,880	13,950	12,240	15,300
16	13,680	14,400	14,220	15,840	14,670	17,280	14,688	18,360
18	16,200	17,100	17,010	18,900	17,100	20,250	17,280	21,600
20	19,620	20,700	20,250	22,500	21,420	25,200	25,920	32,400
24	27,900	29,700	30,780	34,200	33,660	39,600	45,360	56,700
28	35,010	37,980	40,410	45,720	45,540	54,810	68,580	91,980
30	41,760	45,180	49,860	55,890	57,420	68,130	88,020	117,090

NOTE

> For sizes not shown, contact Bray for more information.

ASME CLASS 300 – SERIES 42/43/4B

STANDARD VALVE – TORQUE VALUES (Lb-in)								
Valve Differential Pressure (psig)								
NPS	<150 psig		>150 to 350 psig		>350 to 550 psig		>550 to 740 psig	
	Seat Retainer		Seat Retainer		Seat Retainer		Seat Retainer	
	Upstream	Downstream	Upstream	Downstream	Upstream	Downstream	Upstream	Downstream
2	155	180	270	340	360	490	447	559
2½	170	200	290	360	380	510	470	670
3	185	220	310	380	400	530	490	690
4	270	320	420	530	550	730	700	1,000
5	550	650	1,000	1,250	1,390	1,850	1,800	2,550
6	850	1,000	1,320	1,650	1,720	2,300	2,100	3,000
8	1,580	1,850	2,480	3,100	3,230	4,300	3,700	5,300
10	2,800	3,300	4,400	5,500	5,700	7,600	7,000	10,000
12	4,250	5,000	6,640	8,300	8,630	11,500	10,500	15,000
14	7,300	8,600	10,720	13,400	13,700	18,300	15,400	22,000
16	11,900	14,000	17,200	21,500	21,800	29,000	26,600	38,000
18	15,300	18,000	21,600	27,000	27,100	36,100	31,500	45,000
20	20,400	24,000	29,400	36,700	37,000	49,300	42,700	61,000
24	32,300	38,000	45,600	57,000	57,500	76,700	66,500	95,000
30	68,000	80,000	101,600	127,000	129,000	172,000	147,000	210,000
36	101,150	119,000	144,000	180,000	180,000	240,000	203,000	290,000
40	115,600	136,000	168,000	210,000	222,000	296,000	278,600	398,000
48	127,500	150,000	217,600	272,000	321,000	428,000	403,200	576,000

FIRESAFE VALVE – TORQUE VALUES (Lb-in)								
2	672	695	758	803	834	921	845	981
2½	680	720	775	860	860	1,010	880	1,100
3	750	800	855	950	935	1,100	960	1,200
4	850	900	1,080	1,200	1,275	1,500	1,360	1,700
5	1,420	1,500	2,070	2,300	2,635	3,100	2,880	3,600
6	2,000	2,100	2,610	2,900	3,150	3,700	3,440	4,300
8	3,000	3,150	3,870	4,300	4,675	5,500	4,960	6,200
10	6,900	7,300	9,180	10,200	11,050	13,000	12,000	15,000
12	10,450	11,000	13,200	14,700	15,640	18,400	16,800	21,000
14	18,050	19,000	21,600	24,000	22,100	26,000	22,400	28,000
16	26,600	28,000	34,200	38,000	37,400	44,000	39,200	49,000
18	35,300	36,600	43,800	47,400	45,900	52,200	46,900	56,300
20	47,300	48,600	59,800	63,700	63,300	70,000	65,600	75,900
24	73,700	75,400	92,400	97,700	95,700	105,000	97,900	112,300
30	91,300	96,800	125,100	139,400	141,700	165,200	156,500	190,200
36	145,500	154,400	203,300	228,500	232,600	269,700	260,000	312,900

METAL SEATED VALVE – TORQUE VALUES (Lb-in)								
2½	612	648	698	774	774	909	792	990
3	675	720	770	855	842	990	864	1,080
4	765	810	972	1,080	1,148	1,350	1,224	1,530
5	1,278	1,350	1,863	2,070	2,372	2,790	2,592	3,240
6	1,800	1,890	2,349	2,610	2,835	3,330	3,096	3,870
8	2,700	2,835	3,483	3,870	4,208	4,950	4,464	5,580
10	6,210	6,570	8,262	9,180	9,945	11,700	10,800	13,500
12	9,405	9,900	11,880	13,230	14,076	16,560	15,120	18,900
14	16,245	17,100	19,440	21,600	19,890	23,400	20,160	25,200
16	23,940	25,200	30,780	34,200	33,660	39,600	35,280	44,100
20	42,570	43,740	53,820	57,330	56,970	63,000	59,040	68,310
24	66,330	67,860	83,160	87,930	86,130	94,500	88,110	101,070
30	82,170	87,120	112,590	125,460	127,530	148,680	140,850	171,180

NOTE
 > For sizes not shown, contact Bray for more information.

ASME CLASS 600 – SERIES 44/45

STANDARD VALVE – TORQUE VALUES (Lb-in)								
Valve Differential Pressure (psig)								
NPS	<150 psig		>150 to 600 psig		>600 to 1050 psig		>1050 to 1480 psig	
	Seat Retainer		Seat Retainer		Seat Retainer		Seat Retainer	
	Upstream	Downstream	Upstream	Downstream	Upstream	Downstream	Upstream	Downstream
3	400	480	700	870	900	1,200	1,000	1,450
4	850	960	1,280	1,600	1,580	2,100	1,900	2,700
6	1,450	1,700	2,560	3,200	3,450	4,600	4,100	5,800
8	3,500	4,100	5,760	7,200	7,600	10,100	9,800	14,000
10	7,100	8,300	9,600	12,000	13,500	18,000	16,800	24,000
12	10,100	11,800	11,200	14,000	19,500	26,000	21,000	30,000
14	11,900	14,000	19,200	24,000	24,800	33,000	30,000	43,000
16	14,000	16,500	28,400	35,500	34,500	46,000	45,500	65,000
18	16,200	19,000	34,400	43,000	49,000	65,000	64,400	92,000
20	21,300	25,000	45,600	57,000	66,000	88,000	87,000	124,000
24	33,000	39,000	71,000	89,000	94,000	125,000	123,000	175,000
36	69,600	82,500	175,200	219,800	371,400	493,800	405,700	576,400

FIRESAFE VALVE – TORQUE VALUES (Lb-in)								
Valve Differential Pressure (psig)								
NPS	<150 psig		>150 to 600 psig		>600 to 1050 psig		>1050 to 1480 psig	
	Seat Retainer		Seat Retainer		Seat Retainer		Seat Retainer	
	Upstream	Downstream	Upstream	Downstream	Upstream	Downstream	Upstream	Downstream
3	1,217	1,336	1,642	1,678	1,850	2,056	1,795	2,018
4	1,510	1,615	2,021	2,250	2,415	2,936	2,640	3,685
6	2,719	2,950	4,218	5,068	5,790	7,790	5,830	8,100
8	4,422	5,000	7,383	8,657	8,420	12,500	10,760	16,500
10	9,233	8,600	15,400	17,360	20,200	24,500	22,000	26,350
12	15,900	12,100	23,000	25,500	30,700	36,500	33,870	39,500
14	22,300	18,300	30,250	31,800	39,400	45,900	43,900	49,900
16	29,200	26,500	45,400	48,000	62,600	70,300	70,500	96,000
18	41,900	37,400	63,900	70,500	89,100	104,700	80,800	115,100
20	55,100	48,000	86,500	92,800	122,100	138,900	111,500	153,300
24	89,750	66,200	117,500	126,500	165,100	188,800	185,300	208,000
36	142,400	169,300	345,600	351,000	501,800	536,900	577,400	597,700

METAL SEATED VALVE – TORQUE VALUES (Lb-in)								
Valve Differential Pressure (psig)								
NPS	<150 psig		>150 to 600 psig		>600 to 1050 psig		>1050 to 1480 psig	
	Seat Retainer		Seat Retainer		Seat Retainer		Seat Retainer	
	Upstream	Downstream	Upstream	Downstream	Upstream	Downstream	Upstream	Downstream
6	2,447	2,655	3,796	4,562	5,211	7,011	5,247	7,290
8	3,979	4,500	6,644	7,792	7,578	11,250	9,684	14,850
10	8,310	7,740	13,860	15,624	18,180	22,050	19,800	23,715
12	14,310	10,890	20,700	22,950	27,630	32,850	30,483	35,550

NOTE

> For sizes not shown, contact Bray for more information.

SEAT RETAINER POSITION

NOTE

> Valve orientation to media flow affects torque. Values are presented for upstream and downstream orientations.

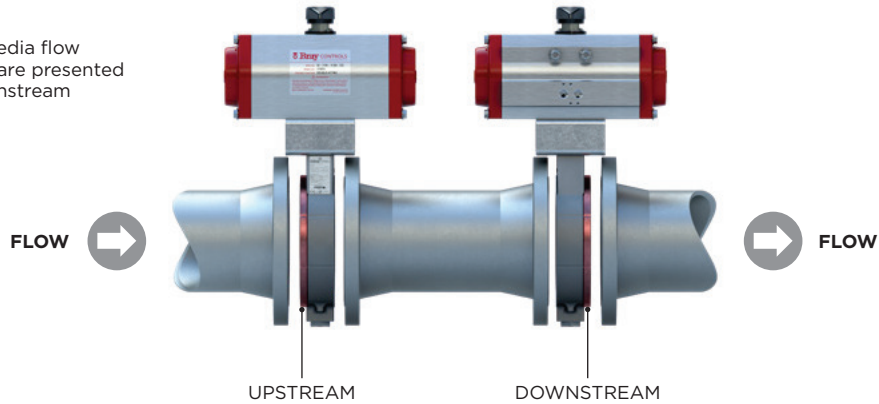

ASME CLASS 150 – SERIES 40/41/4A

STANDARD VALVE – TORQUE VALUES (Nm)								
Valve Differential Pressure (bar)								
DN	<10.3 bar		>10.3 to 14 bar		>14 to 17.2 bar		>17.2 to 20 bar	
	Seat Retainer		Seat Retainer		Seat Retainer		Seat Retainer	
	Upstream	Downstream	Upstream	Downstream	Upstream	Downstream	Upstream	Downstream
50	18	20	19	25	22	29	23	32
65	19	23	21	27	24	32	24	34
80	21	25	24	29	25	34	26	36
100	31	36	34	42	36	47	36	52
125	62	73	72	90	80	106	82	118
150	78	92	87	108	93	124	95	136
200	145	169	158	192	169	220	177	237
250	271	316	298	373	319	425	324	463
300	395	463	452	565	497	667	514	734
350	610	712	669	836	723	960	751	1,073
400	870	1,028	1,021	1,277	1,141	1,525	1,186	1,695
450	1,345	1,582	1,537	1,921	1,695	2,260	1,740	2,486
500	1,729	2,034	1,932	2,407	2,090	2,791	2,135	3,051
600	2,785	3,277	3,127	3,909	3,390	4,531	3,480	4,971
700	3,938	4,632	4,248	5,310	5,005	6,689	5,028	7,175
750	4,514	5,310	4,854	6,067	5,740	7,649	5,932	8,474
800	5,084	5,988	5,514	6,892	6,508	8,677	6,644	9,491
900	6,101	7,231	7,321	9,152	8,304	11,073	8,700	12,428
1,000	7,005	8,248	8,316	10,395	9,321	12,428	9,570	13,671
1,050	8,022	9,378	9,491	11,863	10,762	14,349	11,411	16,157
1,200	11,073	12,993	13,739	17,174	16,100	21,467	17,162	24,518
1,350	15,366	18,078	19,162	23,953	22,371	29,941	23,885	34,121
1500	19,716	23,877	24,962	31,685	29,620	39,606	32,149	45,140

NOTE

> For sizes not shown, contact Bray for more information.

ASME CLASS 150 – SERIES 40/41/4A

FIRESAFE VALVE – TORQUE VALUES (Nm)								
Valve Differential Pressure (bar)								
DN	<10.3 bar		>10.3 to 14 bar		>14 to 17.2 bar		>17.2 to 20 bar	
	Seat Retainer		Seat Retainer		Seat Retainer		Seat Retainer	
	Upstream	Downstream	Upstream	Downstream	Upstream	Downstream	Upstream	Downstream
50	76	79	77	83	78	87	79	90
65	77	81	78	87	79	92	80	95
80	85	90	86	94	87	98	88	102
100	96	102	99	111	101	119	103	124
125	160	169	166	184	169	198	181	209
150	188	198	191	212	203	226	215	237
200	294	316	304	333	311	350	323	362
250	441	475	463	512	480	549	497	576
300	734	780	746	830	757	880	780	915
350	1,390	1,469	1,424	1,582	1,491	1,751	1,537	1,921
400	1,717	1,808	1,785	1,989	1,842	2,169	1,844	2,305
450	2,034	2,147	2,135	2,373	2,147	2,542	2,169	2,712
500	2,463	2,599	2,542	2,825	2,689	3,164	3,254	4,067
600	3,503	3,728	3,864	4,293	4,226	4,971	5,694	7,118
700	4,395	4,768	5,073	5,740	5,717	6,881	8,609	11,547
750	5,242	5,672	6,259	7,016	7,208	8,553	11,050	14,699
800	5,932	6,451	7,265	8,180	8,474	10,101	13,355	17,773
900	7,333	8,598	9,412	11,366	11,219	14,338	18,473	25,738
1000	8,564	10,010	11,016	13,276	13,163	16,823	26,630	33,082
1050	9,400	11,016	1,220	14,733	14,665	18,778	29,873	37,308
1200	12,959	15,309	17,275	20,880	21,072	26,879	42,290	53,690

METAL SEATED VALVE – TORQUE VALUES (Nm)								
Valve Differential Pressure (bar)								
DN	<10.3 bar		>10.3 to 14 bar		>14 to 17.2 bar		>17.2 to 20 bar	
	Seat Retainer		Seat Retainer		Seat Retainer		Seat Retainer	
	Upstream	Downstream	Upstream	Downstream	Upstream	Downstream	Upstream	Downstream
65	69	73	70	78	71	82	72	85
80	76	81	77	84	78	88	79	92
100	86	92	89	100	91	107	93	112
125	144	153	149	166	153	178	163	188
150	169	178	172	191	183	203	193	214
200	264	285	274	300	280	315	291	325
250	397	427	417	461	432	494	447	519
300	661	702	671	747	681	792	702	824
350	1,251	1,322	1,281	1,424	1,342	1,576	1,383	1,729
400	1,546	1,627	1,607	1,790	1,657	1,952	1,660	2,074
450	1,830	1,932	1,922	2,135	1,932	2,288	1,952	2,440
500	2,217	2,339	2,288	2,542	2,420	2,847	2,929	3,661
600	3,152	3,356	3,478	3,864	3,803	4,474	5,125	6,406
700	3,956	4,291	4,566	5,166	5,145	6,193	7,748	10,392
750	4,718	5,105	5,633	6,315	6,488	7,698	9,945	13,229

NOTE

> For sizes not shown, contact Bray for more information.

ASME CLASS 300 – SERIES 42/43/4B

STANDARD VALVE – TORQUE VALUES (Nm)								
Valve Differential Pressure (bar)								
DN	<10.3 bar		>10.3 to 24 bar		>24 to 38 bar		>38 to 51 bar	
	Seat Retainer		Seat Retainer		Seat Retainer		Seat Retainer	
	Upstream	Downstream	Upstream	Downstream	Upstream	Downstream	Upstream	Downstream
50	18	20	31	38	41	55	51	63
65	19	23	33	41	43	58	53	76
80	21	25	35	43	45	60	55	78
100	31	36	47	60	62	82	79	113
125	62	73	113	141	157	209	203	288
150	96	113	149	186	194	260	237	339
200	179	209	280	350	365	486	418	599
250	316	373	497	621	644	859	791	1,130
300	480	565	750	938	975	1,299	1,186	1,695
350	825	972	1,211	1,514	1,548	2,068	1,740	2,486
400	1,345	1,582	1,943	2,429	2,463	3,277	3,005	4,293
450	1,729	2,034	2,440	3,051	3,062	4,079	3,559	5,084
500	2,305	2,712	3,322	4,147	4,180	5,570	4,824	6,892
600	3,649	4,293	5,152	6,440	6,497	8,666	7,513	10,734
750	7,683	9,039	11,479	14,349	14,575	19,433	16,609	23,727
900	11,428	13,445	16,270	20,337	20,337	27,116	22,936	32,766
1,000	13,061	15,366	18,981	23,727	25,083	33,444	31,478	44,968
1,200	14,406	16,948	24,585	30,732	36,268	48,358	45,555	65,079

FIRESAFE VALVE – TORQUE VALUES (Nm)								
50	76	79	86	91	94	104	95	111
65	77	81	88	97	97	114	99	124
80	85	90	97	107	106	124	108	136
100	96	102	122	136	144	169	154	192
125	160	169	234	260	298	350	325	407
150	226	237	295	328	356	418	389	486
200	339	356	437	486	528	621	560	701
250	780	825	1,037	1,152	1,248	1,469	1,356	1,695
300	1,181	1,243	1,491	1,661	1,767	2,079	1,898	2,373
350	2,039	2,147	2,440	2,712	2,497	2,938	2,531	3,164
400	3,005	3,164	3,864	4,293	4,226	4,971	4,429	5,536
450	3,988	4,135	4,949	5,355	5,186	5,898	5,299	6,361
500	5,344	5,491	6,756	7,197	7,152	7,909	7,412	8,576
600	8,327	8,519	10,440	11,039	10,813	11,863	11,061	12,688
750	10,316	10,937	14,134	15,750	16,010	18,665	17,682	21,490
900	16,439	17,445	22,970	25,817	26,280	30,472	29,376	35,353

METAL SEATED VALVE – TORQUE VALUES (Nm)								
65	69	73	79	87	87	103	89	112
80	76	81	87	97	95	112	98	122
100	86	92	110	122	130	153	138	173
125	144	153	210	234	268	315	293	366
150	203	214	265	295	320	376	350	437
200	305	320	394	437	475	559	504	630
250	702	742	933	1,037	1,124	1,322	1,220	1,525
300	1,063	1,119	1,342	1,495	1,590	1,871	1,708	2,135
350	1,835	1,932	2,196	2,440	2,247	2,644	2,278	2,847
400	2,705	2,847	3,478	3,864	3,803	4,474	3,986	4,983
500	4,810	4,942	6,081	6,477	6,437	7,118	6,671	7,718
600	7,494	7,667	9,396	9,935	9,731	10,677	9,955	11,419
750	9,284	9,843	12,721	14,175	14,409	16,799	15,914	19,341

NOTE
 > For sizes not shown, contact Bray for more information.

ASME CLASS 600 – SERIES 44/45

STANDARD VALVE – TORQUE VALUES (Nm)								
Valve Differential Pressure (bar)								
DN	<10.3 bar		>10.3 to 41.4 bar		>41.4 to 72.4 bar		>72.4 to 102 bar	
	Seat Retainer		Seat Retainer		Seat Retainer		Seat Retainer	
	Upstream	Downstream	Upstream	Downstream	Upstream	Downstream	Upstream	Downstream
80	45	54	79	98	102	136	113	164
100	96	108	145	181	179	237	215	305
150	164	192	289	362	390	520	463	655
200	395	463	651	813	859	1,141	1,107	1,582
250	802	938	1,085	1,356	1,525	2,034	1,898	2,712
300	1,141	1,333	1,265	1,582	2,203	2,938	2,373	3,390
350	1,345	1,582	2,169	2,712	2,802	3,728	3,390	4,858
400	1,582	1,864	3,209	4,011	3,898	5,197	5,141	7,344
450	1,830	2,147	3,887	4,858	5,536	7,344	7,276	10,395
500	2,407	2,825	5,152	6,440	7,457	9,943	9,830	14,010
600	3,728	4,406	8,022	10,056	10,621	14,123	13,897	19,772
900	7,864	9,321	19,795	24,834	41,963	55,792	45,838	65,124

FIRESAFE VALVE – TORQUE VALUES (Nm)								
Valve Differential Pressure (bar)								
DN	<10.3 bar		>10.3 to 41.4 bar		>41.4 to 72.4 bar		>72.4 to 102 bar	
	Seat Retainer		Seat Retainer		Seat Retainer		Seat Retainer	
	Upstream	Downstream	Upstream	Downstream	Upstream	Downstream	Upstream	Downstream
80	138	151	186	190	209	232	203	228
100	171	182	228	254	273	332	298	416
150	307	333	477	573	654	880	659	915
200	500	565	834	978	951	1,412	1,216	1,864
250	1,043	972	1,740	1,961	2,282	2,768	2,486	2,977
300	1,796	1,367	2,599	2,881	3,469	4,124	3,827	4,463
350	2,520	2,068	3,418	3,593	4,452	5,186	4,960	5,638
400	3,299	2,994	5,130	5,423	7,073	7,943	7,965	10,847
450	4,734	4,226	7,220	7,965	10,067	11,830	9,129	13,005
500	6,225	5,423	9,773	10,485	13,795	15,694	12,598	17,321
600	10,140	7,480	13,276	14,293	18,654	21,332	20,936	23,501
900	16,089	19,128	39,048	39,658	56,696	60,662	65,237	67,531

METAL SEATED VALVE – TORQUE VALUES (Nm)								
Valve Differential Pressure (bar)								
DN	<10.3 bar		>10.3 to 41.4 bar		>41.4 to 72.4 bar		>72.4 to 102 bar	
	Seat Retainer		Seat Retainer		Seat Retainer		Seat Retainer	
	Upstream	Downstream	Upstream	Downstream	Upstream	Downstream	Upstream	Downstream
150	276	300	429	515	589	792	593	824
200	450	508	751	880	856	1,271	1,094	1,678
250	939	875	1,566	1,765	2,054	2,491	2,237	2,679
300	1,617	1,230	2,339	2,593	3,122	3,712	3,444	4,017

NOTE

> For sizes not shown, contact Bray for more information.

STANDARD / FIRE SAFE / METAL SEATED VALVES

MAXIMUM ALLOWABLE STEM TORQUE VALUES (Lb-in)			
Valve Size inches	ASME 150	ASME 300	ASME 600
	Series 40/41/4A	Series 42/43/4B	Series 44/45
2	1,347	1,347	—
2½	1,968	1,968	—
3	1,968	1,968	3,370
4	1,968	1,968	5,634
5	3,370	3,370	—
6	3,475	5,634	9,945
8	5,544	10,292	27,832
10	9,772	18,511	64,635
12	16,977	27,832	81,356
14	27,832	64,635	136,042
16	64,635	136,042	221,381
18	81,356	136,042	375,962
20	136,042	149,811	643,516
24	149,811	375,962	802,018
28	221,381	—	—
30	375,962	771,674	—
32	375,962	—	—
36	625,815	802,018	1,731,594
40	771,674	1,484,117	—
42	771,674	1,484,117	—
48	802,018	1,622,749	—
54	1,484,117	—	—
60	1,622,749	—	—

MAXIMUM ALLOWABLE STEM TORQUE VALUES (Nm)			
Valve Size mm	ASME 150	ASME 300	ASME 600
	Series 40/41/4A	Series 42/43/4B	Series 44/45
50	152	152	—
65	222	222	—
80	222	222	381
100	222	222	637
125	381	381	—
150	393	637	1,124
200	626	1,163	3,145
250	1,104	2,091	7,303
300	1,918	3,145	9,192
350	3,145	7,303	15,371
400	7,303	15,371	25,013
450	9,192	15,371	42,478
500	15,371	16,926	72,708
600	16,926	42,478	90,616
700	25,013	—	—
750	42,478	87,187	—
800	42,478	—	—
900	70,708	90,616	195,644
1000	87,187	167,683	—
1050	87,187	167,683	—
1200	90,616	183,346	—
1350	167,683	—	—
1500	183,346	—	—

NOTE

¹ Based on stem material 17-4 PH stainless steel, ASTM A564 Type 630 H1150D.

When media flows through a butterfly valve, static pressure does not act uniformly on the surfaces of the valve disc. Dynamic torque will cause rotary motion when unchecked by the actuator or manual operator — possibly resulting in opening or closing of the valve. If the dynamic torque is of a magnitude that is greater than the bearing and packing friction torque, and there is no actuator in place to maintain disc position — the opening or closing action could result in injury to operating personnel, or an interruption of the process. Sudden closure (slamming) can cause water hammer damage in lines carrying liquid.

In high performance butterfly valves, which have the disc offset from the stem and have non-symmetrical disc faces, **dynamic torque acts to close the valve, if the valve is installed with the seat retainer downstream — but can act to close or open the valve, depending on the position of the disc, if the seat retainer is upstream.**

Seat Retainer Upstream

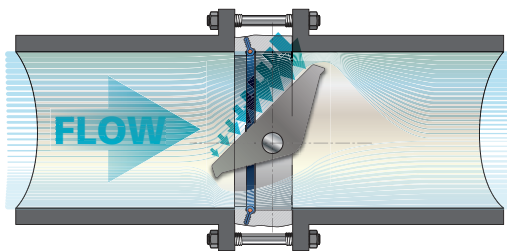

Seat Retainer Downstream

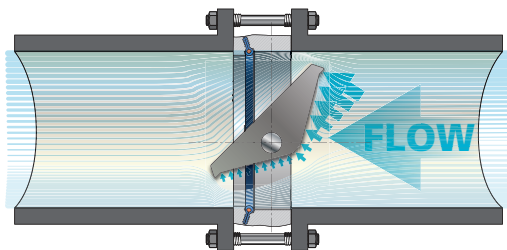

Dynamic torque should be calculated as part of the valve actuator sizing procedure, or to determine if hand lever operation is acceptable. In this regard, the total torque of all service conditions must be considered.

The total torque, when the disc is in the seat, consists of:

- > Seating torque
- > Stem packing torque
- > Eccentricity torque
- > Stem bearing torque

The total torque when the disc is in the seat is published as seating/unseating torque. When the disc is out of the seat, the total torque consists of dynamic torque, stem packing torque, and stem bearing torque.

Total torque changes with the disc position. Maximum total torque can occur at shutoff (disc in the seat), at breakaway (motion initiation), or at any open disc position where the product of valve pressure drop and dynamic torque coefficient peaks, in combination with prevailing bearing and packing torque.

ESTIMATING DYNAMIC TORQUE

Dynamic torque can be estimated using the following empirical equations:

Liquid Flow

$$\text{Imperial } T_d \text{ (Lb-in)} = C_{dt} D^3 \Delta P$$

$$\text{Metric } T_d \text{ (N-m)} = .0001 C_{dt} D^3 \Delta P$$

Gas Flow

$$\text{Imperial } T_d \text{ (Lb-in)} = C_{dt} D^3 Y \Delta P$$

$$\text{Metric } T_d \text{ (N-m)} = .0001 C_{dt} D^3 Y \Delta P$$

DYNAMIC TORQUE TERMINOLOGY

- C_{dt}** dynamic torque coefficient
(see graphs and tables on page 33 for values of C_{dt})
Positive value of C_{dt} means that the dynamic torque acts to close the valve and a negative value of C_{dt} to open the valve.
- D** nominal valve size (in or mm)
- F_k** ratio of specific heat factor (dimensionless)
F_k = k/1.40 or F_k = 1 for air
- k** ratio of specific heat (dimensionless)
- ΔP** effective pressure drop across the valve (psi or bar)
- p₁** valve inlet pressure (psia or bar abs.)
- T_d** dynamic torque (Lb-in or N-m)
- x** x = ΔP/p₁
- Y** gas expansion factor (dimensionless)
Y = 1 - x / (3 F_k x_t)
- x_t** gas critical pressure ratio (dimensionless)
Values of x_t change with disc position and are identical for seat retainer upstream and downstream.

° Open	x _t	° Open	x _t
10	0.46	55	0.31
15	0.46	60	0.28
20	0.46	65	0.27
25	0.45	70	0.25
30	0.44	75	0.24
35	0.42	80	0.22
40	0.39	85	0.21
45	0.35	90	0.19
50	0.33		

C_{dt} VALUES | Seat Retainer Downstream

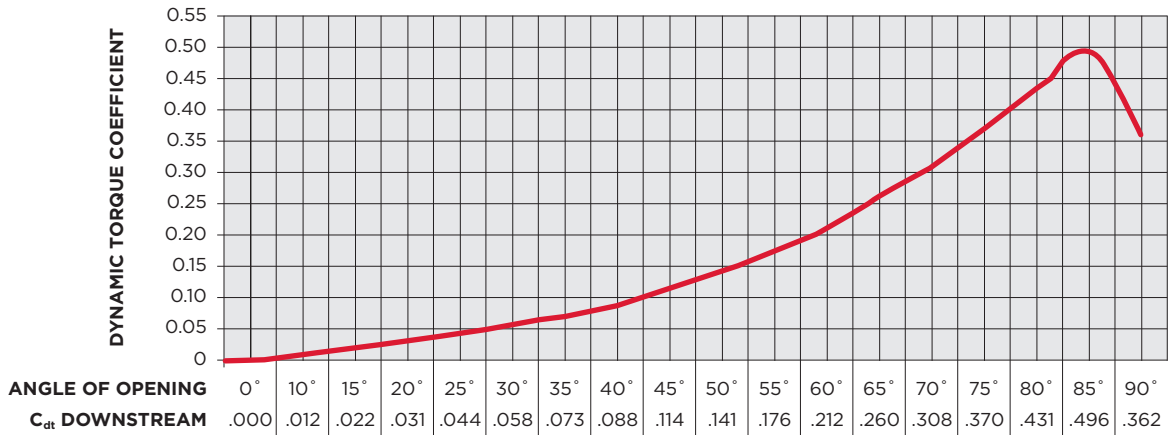

C_{dt} VALUES | Seat Retainer Upstream

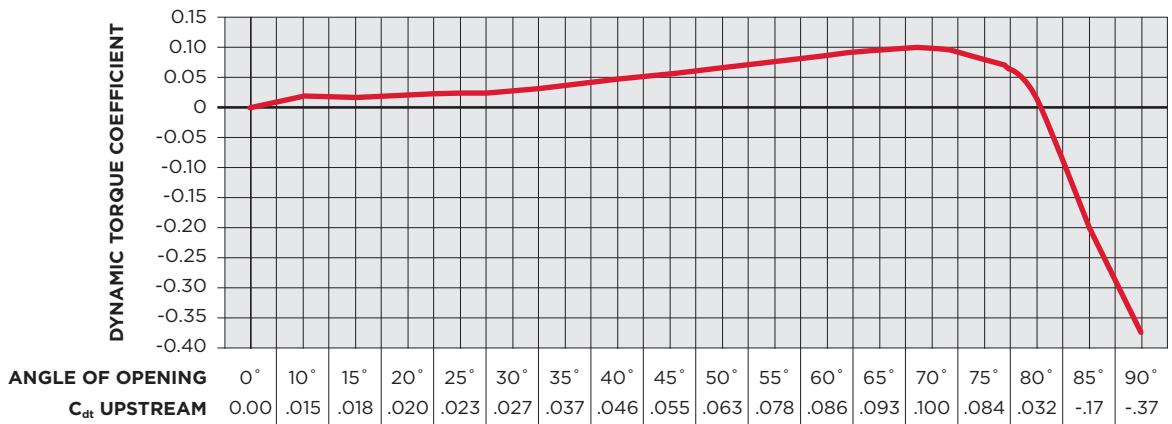

SUBCHOKED AND CHOKED FLOW

For	Condition	Use	Note
Subchoked Flow	Pipe and Valve Size Equal	Nominal Valve Size	
		Valve Pressure Drop	
		C_{qt} from Pressure/Temperature graphs (pages 11 and 12)	
	With Pipe Reducers	Nominal Valve Size	
		C_{qt} from Pressure/Temperature graphs (pages 11 and 12)	
		Valve Pressure Drop as if valve were installed in valve-sized pipe with same flow rate	
Choked Flow	Pipe and Valve Size Equal	Nominal Valve Size	If actual pressure drop at the choked condition is not known, estimate by evaluating the pressure in the piping at the valve outlet needed to sustain the choked flow rate through the piping downstream of the valve; then subtracting it from the valve inlet pressure.
		C_{qt} from Pressure/Temperature graphs (pages 11 and 12)	
		Actual Pressure drop through valve	
	With Pipe Reducers	Nominal Valve Size	If the pressure drop at the choked condition is not known, estimate the line pressure just downstream of the valve/reducer assembly which is needed to sustain the choked flow rate of the valve/reducer assembly through the downstream piping; then subtract this pressure from the line pressure just ahead of the valve/reducer assembly, to get the actual pressure drop.
C_{qt} from Pressure/Temperature graphs (pages 11 and 12)			
Actual pressure drop through valve/reducer assembly			

For	Condition	Use	Note
Subchoked Flow	Pipe and Valve Size Equal	Nominal Valve Size	
		Valve Pressure Drop	
		C_{qt} from Pressure/Temperature graphs (pages 11 and 12)	
	With Pipe Reducers	Nominal Valve Size	To calculate Y — use the line pressure just upstream of the inlet reducer for p_1 , and x_t from Dynamic Torque Coefficient curves (page 33).
C_{qt} from Pressure/Temperature graphs (pages 11 and 12)			
Valve Pressure Drop (and expansion factor Y) as if valve were installed in valve-sized pipe with same flow rate			
Choked Flow	Pipe and Valve Size Equal	Nominal Valve Size	Use x_t from Dynamic Torque Coefficient curves (page 33).
		Gas expansion factor Y of 2/3	
		C_{qt} from Pressure/Temperature graphs (pages 11 and 12)	
		$\Delta P = p_1 F_k X_t$	
With Pipe Reducers	Pipe and Valve Size Equal	Nominal Valve Size	To calculate ΔP — use the line pressure just upstream of the inlet reducer for p_1 , and x_t from Dynamic Torque Coefficient curves (page 33).
		Gas expansion factor Y of 2/3	
		C_{qt} from Pressure/Temperature graphs (pages 11 and 12)	
	$\Delta P = p_1 F_k X_t$		

SUBCHOKED LIQUID FLOW | Line-Size Valve

Example Calculations	Data
A 24 inch Class 150 McCannalok is to be installed in a 24 inch line carrying water. It has been determined that the flow is not choked and the following pressure drops through the valve have been calculated:	75 psi with the valve 20 degrees open 70 psi with the valve 30 degrees open 35 psi with the valve 40 degrees open 3.5 psi with the valve 55 degrees open 1.1 psi with the valve 60 degrees open .20 psi with the valve 70 degrees open .05 psi with the valve 80 degrees open .03 psi with the valve 90 degrees open
Estimate the maximum dynamic torque in Lb-in for the valve considering installation with the seat retainer upstream.	$T_d = C_{dt} D^3 \Delta P$
Substituting produces following results:	20 degrees, $T_d = .020 \times 24^3 \times 75 = 20,700$ Lb-in (tends to close the valve) 30 degrees, $T_d = .027 \times 24^3 \times 70 = 26,100$ Lb-in 40 degrees, $T_d = .046 \times 24^3 \times 35 = 22,300$ Lb-in 55 degrees, $T_d = .078 \times 24^3 \times 3.5 = 3,800$ Lb-in 60 degrees, $T_d = .086 \times 24^3 \times 1.1 = 1,300$ Lb-in 70 degrees, $T_d = .100 \times 24^3 \times .20 = 300$ Lb-in 80 degrees, $T_d = .032 \times 24^3 \times .05 = 20$ Lb-in 90 degrees, $T_d = -.369 \times 24^3 \times .03 = -150$ Lb-in (tends to open the valve)
Thus the peak dynamic torque will occur between 30 and 40 degrees open.	
Verify dynamic torque at 35 degrees:	Approximate pressure drop = $(70+35)/2 = 52.5$ psi. At 35 degrees: $T_d = .037 \times 24^3 \times 52.5 = 27,000$ Lb-in
The peak dynamic torque of approximately 27,000 Lb-in occurs at about 35 degrees open.	
When sizing the valve operator, total torque must be considered. The total torque when the disc is in the seat consists of seating torque, stem packing torque, eccentricity torque and stem bearing torque. The total torque when the disc is in the seat is published as seating/unseating torque (pages 23 thru 30). When the disc is out of the seat, total torque consists of dynamic torque, stem packing torque, and stem bearing torque.	

CHOKED GAS FLOW | Reduced-Size Valve

Example Calculations	Data
(DN 500) Class 300 McCannalok butterfly valve is installed in a (600 mm) line flowing air and the disc is set at 45 degrees. The flow is choked. A pressure gauge tapped into the pipe just above the upstream reducer shows 24.5 bar.	
Estimate the dynamic torque in N-m, given that the seat retainer is installed downstream.	D = 500 mm $F_k = 1.0$ $C_t = .114$ Y = .667 for choked flow $p_1 = 24.5 + 1.0 = 25.5$ bar absolute, (1 atm. = 1.013 bar, i.e. about 1.0 bar) x_c at 45° = .35
Calculations: $\Delta P = p_1 F_k x_c$ $\Delta P = 25.5 \times 1.0 \times .35 = 8.9$ bar $T_d = .0001 C_t D^3 Y \Delta p$ $T_d = .0001 \times .114 \times 500^3 \times .667 \times 8.9 = 8,500$ N-m	
Thus the dynamic torque at 45 degrees open is about 8,500 N-m, and acts to close the valve.	

STANDARD / FIRESAFE / METAL SEATED

ASME CLASS 150 — SERIES 40/41/4A — Cv VALUES									
NPS	DISC POSITION (Degrees)								
	90°	80°	70°	60°	50°	40°	30°	20°	10°
2	87	77	65	51	37	25	14	8	6
2½	160	136	100	78	50	30	16	8	3
3	185	178	155	123	87	56	32	14	5
4	375	365	315	250	175	115	63	31	10
5	790	675	500	360	238	146	78	41	16
6	1,350	1,070	750	510	330	218	140	81	35
8	2,800	2,230	1,590	1,060	685	456	280	165	65
10	4,300	3,450	2,430	1,630	1,050	700	450	250	100
12	6,650	5,330	3,750	2,530	1,630	1,080	700	390	155
14	7,650	6,100	4,300	2,900	1,890	1,250	810	450	175
16	9,800	7,860	5,510	3,700	2,420	1,530	1,020	580	230
18	10,500	9,100	6,960	5,100	3,520	2,220	1,180	500	170
20	13,500	11,700	8,800	6,500	4,500	2,820	1,530	640	200
24	20,000	17,100	12,800	9,570	6,640	3,880	2,200	920	240
26	20,000	17,100	12,800	9,570	6,640	3,880	2,200	920	240
28	28,000	23,900	18,200	13,500	9,300	5,700	3,100	1,300	290
30	32,000	27,300	20,900	15,500	10,700	6,700	3,600	1,510	320
32	34,000	29,100	22,300	16,500	11,400	7,150	3,850	1,610	340
34	34,000	29,100	22,300	16,500	11,400	7,150	3,850	1,610	340
36	48,500	41,100	31,700	23,200	16,400	10,200	5,430	2,260	480
40	62,000	55,200	44,000	33,300	23,800	15,200	8,600	3,520	670
42	65,000	58,000	46,100	35,000	25,000	16,000	9,000	3,700	700
48	91,000	80,900	63,700	43,600	29,100	20,000	11,000	4,600	920
54	125,000	111,000	87,500	60,000	40,000	27,500	15,000	6,000	1,200
60	160,000	140,000	105,000	75,000	50,000	31,000	17,000	7,000	1,400

ASME CLASS 300 — SERIES 42/43/4B — Cv VALUES									
NPS	DISC POSITION (Degrees)								
	90°	80°	70°	60°	50°	40°	30°	20°	10°
2	87	77	65	51	37	25	14	8	6
2½	160	136	100	78	50	30	16	8	3
3	185	178	155	123	87	56	32	14	5
4	375	365	315	250	175	115	63	31	10
5	790	675	500	360	238	146	78	41	16
6	1,000	875	710	530	370	240	138	79	26
8	2,000	1,720	1,360	950	630	405	240	121	47
10	2,650	2,250	1,740	1,200	780	510	295	150	61
12	4,000	3,400	2,500	1,690	1,100	710	430	220	92
14	4,100	3,500	2,600	1,770	1,200	830	490	240	100
16	7,800	6,540	4,550	2,970	1,840	1,160	730	420	180
18	9,500	8,000	6,170	4,530	3,110	1,970	1,080	440	94
20	11,000	9,570	7,300	5,400	3,720	2,330	1,250	530	110
24	18,000	15,100	11,400	8,570	5,920	3,700	2,000	830	180
30	29,000	24,400	18,900	13,700	8,500	6,000	3,230	1,330	290
36	45,000	38,100	29,200	21,000	14,800	9,100	4,660	1,730	380
42	60,000	54,000	42,000	30,000	19,000	13,000	7,500	2,600	450
48	83,000	74,000	58,000	41,000	26,000	17,000	10,000	4,400	800

ASME CLASS 600 — SERIES 44/45 — Cv VALUES									
NPS	DISC POSITION (Degrees)								
	90°	80°	70°	60°	50°	40°	30°	20°	10°
3	165	158	135	103	67	46	12	8	3
4	300	270	210	150	95	70	45	30	5
6	800	765	600	425	270	200	130	70	15
8	1,500	1,350	1,050	750	480	345	209	78	20
10	2,200	1,970	1,540	1,100	700	500	300	140	40
12	3,100	2,790	2,170	1,550	1,000	680	400	190	55
14	3,900	3,300	2,400	1,570	1,100	730	420	200	70
16	5,000	4,200	2,900	1,900	1,200	800	500	250	95
18	6,000	5,000	3,900	2,800	1,900	1,200	660	290	130
20	8,000	6,900	5,300	3,900	2,700	1,700	950	400	143
24	11,000	9,300	7,000	5,200	3,600	2,250	1,200	500	180
30	15,000	13,000	10,000	8,400	5,100	2,800	1,650	600	200

NOTES

- > Cv varies with the valve size, angle of opening and the manufacturer's valve style.
- > Cv value is the volume of water in USGPM that will flow through a given restriction or valve opening with a pressure drop of one (1) psi at room temperature.

STANDARD / FIRESAFE / METAL SEATED

ASME CLASS 150 – SERIES 40/41/4A – Kv VALUES									
DN	DISC POSITION (Degrees)								
	90°	80°	70°	60°	50°	40°	30°	20°	10°
50	74	65	55	43	31	21	12	7	5
65	136	116	85	67	43	26	14	7	3
80	158	152	132	105	74	48	27	12	4
100	320	311	269	213	149	98	54	26	9
125	674	576	427	307	203	125	67	35	14
150	1,152	913	640	435	281	186	119	69	30
200	2,388	1,902	1,356	904	584	389	239	141	55
250	3,668	2,943	2,073	1,390	896	597	384	213	85
300	5,672	4,546	3,199	2,158	1,390	921	597	333	132
350	6,525	5,203	3,668	2,474	1,612	1,066	691	384	149
400	8,359	6,705	4,700	3,156	2,064	1,305	870	495	196
450	8,957	7,762	5,937	4,350	3,003	1,894	1,007	427	145
500	11,516	9,980	7,506	5,545	3,839	2,405	1,305	546	171
600	17,060	14,586	10,918	8,163	5,664	3,310	1,877	785	205
650	17,060	14,586	10,918	8,163	5,664	3,310	1,877	785	205
700	23,884	20,387	15,525	11,516	7,933	4,862	2,644	1,109	247
750	27,296	23,287	17,828	13,222	9,127	5,715	3,071	1,288	273
800	29,002	24,822	19,022	14,075	9,724	6,099	3,284	1,373	290
850	29,002	24,822	19,022	14,075	9,724	6,099	3,284	1,373	290
900	41,371	35,058	27,040	19,790	13,989	8,701	4,632	1,928	409
1000	52,886	47,086	37,532	28,405	20,301	12,966	7,336	3,003	572
1050	55,445	49,474	39,323	29,855	21,325	13,648	7,677	3,156	597
1200	77,623	69,008	54,336	37,191	24,822	17,060	9,383	3,924	785
1350	106,625	94,683	74,638	51,180	34,120	23,458	12,795	5,118	1,024
1500	136,480	119,420	89,565	63,975	42,650	26,443	14,501	5,971	1,194

ASME CLASS 300 – SERIES 42/43/4B – Kv VALUES									
50	74	65	55	43	31	21	12	7	5
65	136	116	85	67	43	26	14	7	3
80	158	152	132	105	74	48	27	12	4
100	320	311	269	213	149	98	54	26	9
125	674	576	427	307	203	125	67	35	14
150	853	746	606	452	316	205	118	67	22
200	1,706	1,467	1,160	810	537	345	205	103	40
250	2,260	1,919	1,484	1,024	665	435	252	128	52
300	3,412	2,900	2,133	1,442	938	606	367	188	78
350	3,497	2,986	2,218	1,510	1,024	708	418	205	85
400	6,653	5,579	3,881	2,533	1,570	989	623	358	154
450	8,104	6,824	5,263	3,864	2,653	1,680	921	375	80
500	9,383	8,163	6,227	4,606	3,173	1,987	1,066	452	94
600	15,354	12,880	9,724	7,310	5,050	3,156	1,706	708	154
750	24,737	20,813	16,122	11,686	7,251	5,118	2,755	1,134	247
900	38,385	32,499	24,908	17,913	12,624	7,762	3,975	1,476	324
1050	51,180	46,062	35,826	25,590	16,207	11,089	6,398	2,218	384
1200	70,799	63,122	49,474	34,973	22,178	14,501	8,530	3,753	682

ASME CLASS 600 – SERIES 44/45 – Kv VALUES									
80	141	135	115	88	57	39	10	7	3
100	256	230	179	128	81	60	38	26	4
150	735	662	519	368	234	173	112	61	13
200	1,280	1,152	896	640	409	294	178	67	17
250	1,877	1,680	1,314	938	597	427	256	119	34
300	2,644	2,380	1,851	1,322	853	580	341	162	47
350	3,327	2,815	2,047	1,339	938	623	358	171	60
400	4,265	3,583	2,474	1,621	1,024	682	427	213	81
450	5,118	4,265	3,327	2,388	1,621	1,024	563	247	111
500	6,824	5,886	4,521	3,327	2,303	1,450	810	341	122
600	9,383	7,933	5,971	4,436	3,071	1,919	1,024	427	154
750	12,795	11,089	8,530	7,165	4,350	2,388	1,407	512	171

NOTES

- > Kv varies with the valve size, angle of opening and the manufacturer's valve style.
- > Kv value is the volume of water in cubic meters/hour (m³/hr) that will flow through a given restriction or valve opening with a pressure drop of one (1) bar at room temperature.

WAFER VALVE WITH THRU STUDS

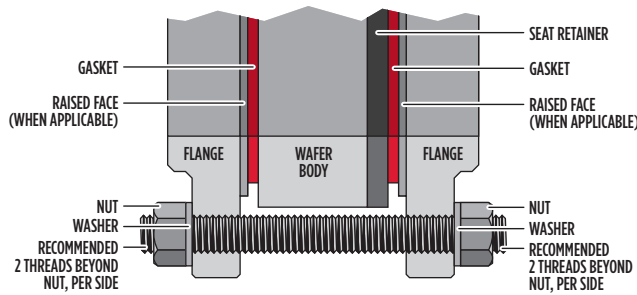

THRU STUD LENGTH										
Nut Thickness (X2)	+	Washer Thickness (X2)	+	Flange Thickness (X2)	+	Gasket Thickness (X2)	+	Valve Face to Face	=	Length of Stud
PLUS 2 THREADS PER NUT			INCLUDE RAISED FACE, IF APPLICABLE			INCLUDE SEAT RETAINER				

LUG VALVE WITH STUDS

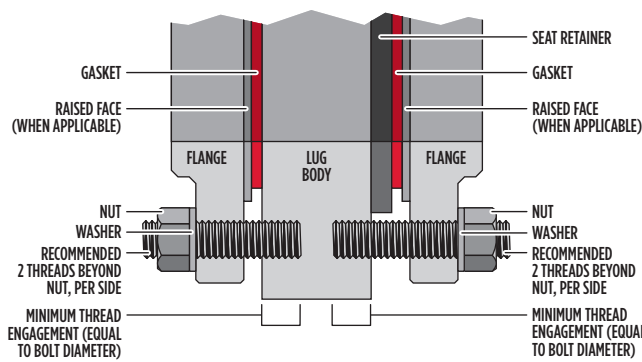

STUD LENGTH												
Nut Thickness	+	Washer Thickness	+	Flange Thickness	+	Gasket Thickness	+	Seat Retainer Ring Raised Face	+	Minimum Thread Engagement	=	Length of Stud
PLUS 2 THREADS PER NUT			INCLUDE RAISED FACE, IF APPLICABLE			SEAT RETAINER SIDE ONLY			ONE BOLT DIAMETER			

LUG VALVE WITH HEX HEAD BOLTS

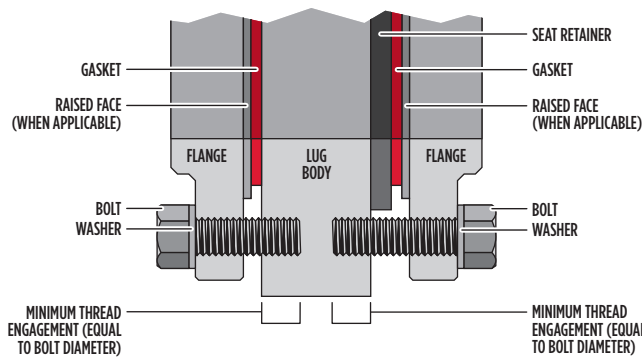

HEX HEAD BOLT LENGTH										
Washer Thickness	+	Flange Thickness	+	Gasket Thickness	+	Seat Retainer Ring Raised Face	+	Minimum Thread Engagement	=	Length of Bolt
INCLUDE RAISED FACE, IF APPLICABLE			SEAT RETAINER SIDE ONLY			ONE BOLT DIAMETER				

IMPORTANT INFORMATION



CAUTION
Tapped holes at neck locations do not permit through-holes.

NOTES

- > Double flange style bolting not shown.
- > Refer to appropriate Bray dimensional drawings for specific valve drilling information.
- > Lug threads may be tapped from both sides, and therefore tap may not be continuous.
- > Minimum bolt engagement must be equal to the diameter of the bolt.
- > When bolting the valve into the line, use standard bolting torque as recommended by applicable piping standards. Additional force from the flange bolts is not required.

ASSUMPTIONS MADE IN CALCULATIONS

- > Lengths rounded to the nearest 1/4 inch for maximum thread engagement.
- > Nut thickness as per ASME B18.2.2 Heavy Hex.
- > Washer thickness as per ASME B18.22.1 Type A.
- > Flange thickness as per ASME B16.5 or ASME B16.47 Series A.
- > Gasket thickness = .175 inch.
- > Raised face = .06 inch.

ASME CLASS 150 | SERIES 40 WAFER STYLE | THRU STUD LENGTH

Valve Size			Fastener Size			Thru Stud			Retainer Blind Stud			Back Blind Stud		
NPS	DN	Ø-Thread	in	mm	Qty	in	mm	Qty	in	mm	Qty	in	mm	Qty
2	50	5/8-11 UNC	5.50	140	4	—	—	—	—	—	—	—	—	—
2½	65	5/8-11 UNC	6.00	152	4	—	—	—	—	—	—	—	—	—
3	80	5/8-11 UNC	6.00	152	4	—	—	—	—	—	—	—	—	—
4	100	5/8-11 UNC	6.25	159	8	—	—	—	—	—	—	—	—	—
5	125	¾-10 UNC	6.75	171	8	—	—	—	—	—	—	—	—	—
6	150	¾-10 UNC	7.00	178	8	—	—	—	—	—	—	—	—	—
8	200	¾-10 UNC	7.50	191	8	—	—	—	—	—	—	—	—	—
10	250	7/8-9 UNC	8.25	210	12	—	—	—	—	—	—	—	—	—
12	300	7/8-9 UNC	8.50	216	12	—	—	—	—	—	—	—	—	—
14	350	1-8 UNC	9.75	248	12	—	—	—	—	—	—	—	—	—
16	400	1-8 UNC	10.25	260	16	—	—	—	—	—	—	—	—	—
18	450	1 1/8-8 UN	11.25	286	16	—	—	—	—	—	—	—	—	—
20	500	1 1/8-8 UN	12.00	305	16	+	5.50	140	4	4.50	114	4	—	—
24	600	1 1/4-8 UN	13.25	337	20	+	—	—	—	—	—	—	—	—
26	650	1 1/4-8 UN	15.75	400	20	+	6.75	171	4	6.00	152	4	—	—
28	700	1 1/4-8 UN	15.75	400	24	+	6.75	171	4	6.00	152	4	—	—
30	750	1 1/4-8 UN	17.00	432	24	+	7.50	191	4	6.00	152	4	—	—
32	800	1 1/4-8 UN	18.25	464	24	+	7.75	197	4	7.00	178	4	—	—
36	900	1 1/2-8 UN	19.75	502	28	+	8.25	210	4	7.25	184	4	—	—
42	1050	1 1/2-8 UN	21.50	546	32	+	8.00	203	4	7.50	191	4	—	—
48	1200	1 1/2-8 UN	22.75	578	40	+	8.25	210	4	7.75	197	4	—	—
54	1350	1 3/4-8 UN	25.00	635	40	+	10.00	254	4	8.75	222	4	—	—

ASME CLASS 150 | SERIES 41 LUG STYLE | STUD LENGTH

Valve Size			Fastener Size			Retainer Side Stud			Back Side Stud			Retainer Blind Stud			Back Blind Stud		
NPS	DN	Ø-Thread	in	mm	Qty	in	mm	Qty	in	mm	Qty	in	mm	Qty	in	mm	Qty
2½	65	5/8-11 UNC	3.00	76	4	2.75	70	4	—	—	—	—	—	—	—	—	—
3	80	5/8-11 UNC	3.00	76	4	2.75	70	4	—	—	—	—	—	—	—	—	—
4	100	5/8-11 UNC	3.25	83	8	2.75	70	8	—	—	—	—	—	—	—	—	—
5	125	¾-10 UNC	3.25	83	8	2.75	70	8	—	—	—	—	—	—	—	—	—
6	150	¾-10 UNC	3.50	89	8	3.25	83	8	—	—	—	—	—	—	—	—	—
8	200	¾-10 UNC	3.75	95	8	3.25	83	8	—	—	—	—	—	—	—	—	—
10	250	7/8-9 UNC	4.00	102	12	3.75	95	12	—	—	—	—	—	—	—	—	—
12	300	7/8-9 UNC	4.25	108	12	4.00	102	12	—	—	—	—	—	—	—	—	—
14	350	1-8 UNC	5.00	127	12	4.25	108	12	—	—	—	—	—	—	—	—	—
16	400	1-8 UNC	5.00	127	16	4.75	121	16	—	—	—	—	—	—	—	—	—
18	450	1 1/8-8 UN	5.50	140	16	5.25	133	16	—	—	—	—	—	—	—	—	—
20	500	1 1/8-8 UN	5.50	140	16	5.50	140	16	+	5.50	140	4	4.50	114	4	—	—
24	600	1 1/4-8 UN	6.50	165	20	6.25	159	20	+	—	—	—	—	—	—	—	—
28	700	1 1/4-8 UN	7.00	178	24	7.25	184	24	+	7.00	178	4	6.00	152	4	—	—
30	750	1 1/4-8 UN	7.50	191	24	7.25	184	24	+	7.50	191	4	6.25	159	4	—	—
32	800	1 1/2-8 UN	8.00	203	24	8.00	203	24	+	8.00	203	4	7.00	178	4	—	—
36	900	1 1/2-8 UN	8.25	210	28	8.25	210	28	+	8.25	210	4	7.25	184	4	—	—
40	1000	1 1/2-8 UN	8.00	203	32	8.75	222	32	+	8.00	203	4	7.25	184	4	—	—
42	1050	1 1/2-8 UN	8.25	210	32	9.25	235	32	+	8.25	210	4	7.50	191	4	—	—
48	1200	1 1/2-8 UN	8.50	216	40	9.75	248	40	+	8.50	216	4	8.00	203	4	—	—
54	1350	1 3/4-8 UN	9.50	241	40	10.75	273	40	+	9.50	241	4	8.50	216	4	—	—
60	1500	1 3/4-8 UN	10.25	260	42	9.25	235	42	+	10.25	260	10	9.25	235	10	—	—

ASME CLASS 150 | SERIES 41 LUG STYLE | BOLT LENGTH

Valve Size			Fastener Size			Retainer Side Hex Head Bolt			Back Side Hex Head Bolt			Retainer Blind Hex Head Bolt			Back Blind Hex Head Bolt		
NPS	DN	Ø-Thread	in	mm	Qty	in	mm	Qty	in	mm	Qty	in	mm	Qty	in	mm	Qty
2½	65	5/8-11 UNC	2.25	57	4	1.75	44	4	—	—	—	—	—	—	—	—	—
3	80	5/8-11 UNC	2.25	57	4	2.00	51	4	—	—	—	—	—	—	—	—	—
4	100	5/8-11 UNC	2.25	57	8	2.00	51	8	—	—	—	—	—	—	—	—	—
5	125	¾-10 UNC	2.25	57	8	2.25	57	8	—	—	—	—	—	—	—	—	—
6	150	¾-10 UNC	2.50	64	8	2.00	51	8	—	—	—	—	—	—	—	—	—
8	200	¾-10 UNC	2.50	64	8	2.50	64	8	—	—	—	—	—	—	—	—	—
10	250	7/8-9 UNC	2.75	70	12	2.75	70	12	—	—	—	—	—	—	—	—	—
12	300	7/8-9 UNC	3.00	76	12	3.00	76	12	—	—	—	—	—	—	—	—	—
14	350	1-8 UNC	3.75	95	12	3.25	83	12	—	—	—	—	—	—	—	—	—
16	400	1-8 UNC	3.75	95	16	3.25	83	16	—	—	—	—	—	—	—	—	—
18	450	1½-8 UN	4.25	108	16	4.00	102	16	—	—	—	—	—	—	—	—	—
20	500	1½-8 UN	4.25	108	16	4.25	108	16	+	4.25	108	4	3.50	89	4	—	—
24	600	1¼-8 UN	5.00	127	20	4.75	121	20	+	—	—	—	—	—	—	—	—
28	700	1¼-8 UN	5.50	140	24	5.75	146	24	+	5.25	133	4	4.50	114	4	—	—
30	750	1¼-8 UN	6.00	152	24	5.75	146	24	+	5.75	146	4	4.50	114	4	—	—
32	800	1½-8 UN	6.25	159	24	6.50	165	24	+	6.00	152	4	4.75	121	4	—	—
36	900	1½-8 UN	6.75	171	28	6.75	171	28	+	6.25	159	4	5.25	133	4	—	—
40	1000	1½-8 UN	6.50	165	32	7.25	184	32	+	6.00	152	4	5.25	133	4	—	—
42	1050	1½-8 UN	6.50	165	32	7.50	191	32	+	6.25	159	4	5.75	146	4	—	—
48	1200	1½-8 UN	6.75	171	40	8.00	203	40	+	6.50	165	4	6.25	159	4	—	—
54	1350	1¾-8 UN	7.75	197	40	8.75	222	40	+	7.25	184	4	6.50	165	4	—	—
60	1500	1¾-8 UN	8.50	216	42	7.50	191	42	+	8.25	210	10	7.00	178	10	—	—

ASME CLASS 150 | SERIES 4A DOUBLE FLANGE STYLE | BOLT LENGTH

Valve Size			Fastener Size			Retainer Side Hex Head Bolt			Back Side Hex Head Bolt			Retainer Blind Hex Head Bolt		
NPS	DN	Ø-Thread	in	mm	Qty	in	mm	Qty	in	mm	Qty	in	mm	Qty
3	80	5/8-11 UNC	3.50	89	4	3.25	83	4	—	—	—	—	—	—
4	100	5/8-11 UNC	3.75	95	6	3.25	83	8	+	2.25	57	2	—	—
5	125	¾-10 UNC	3.75	95	6	3.25	83	8	+	2.50	64	2	—	—
6	150	¾-10 UNC	4.00	102	6	3.50	89	8	+	2.50	64	2	—	—
8	200	¾-10 UNC	4.25	108	6	3.75	95	8	+	2.50	64	2	—	—
10	250	7/8-9 UNC	4.50	114	10	4.00	102	12	+	2.75	70	2	—	—
12	300	7/8-9 UNC	5.00	127	8	4.25	108	12	+	2.75	70	4	—	—
14	350	1-8 UNC	5.25	133	8	4.50	114	12	+	3.25	83	4	—	—
16	400	1-8 UNC	5.50	140	12	4.75	121	16	+	3.25	83	4	—	—
18	450	1½-8 UN	5.75	146	12	5.00	127	16	+	3.50	89	4	—	—
20	500	1½-8 UN	6.00	152	16	5.25	133	20	+	3.50	89	4	—	—
24	600	1¼-8 UN	6.75	172	16	5.75	146	20	+	4.00	102	4	—	—
30	750	1¼-8 UN	9.50	241	24	8.00	203	28	+	5.25	133	4	—	—

ASME CLASS 300 | SERIES 42 WAFER STYLE | THRU STUD LENGTH

Valve Size			Fastener Size			Thru Stud			Retainer Blind Stud			Back Blind Stud			
NPS	DN	Ø-Thread	in	mm	Qty	in	mm	Qty	in	mm	Qty	in	mm	Qty	
2½	65	¾-10 UNC	6.25	159	8	—	—	—	—	—	—	—	—	—	
3	80	¾-10 UNC	6.50	165	8	—	—	—	—	—	—	—	—	—	
4	100	¾-10 UNC	7.00	178	8	—	—	—	—	—	—	—	—	—	
5	125	¾-10 UNC	7.50	191	8	—	—	—	—	—	—	—	—	—	
6	150	¾-10 UNC	7.75	197	12	—	—	—	—	—	—	—	—	—	
8	200	7/8-9 UNC	8.75	222	12	—	—	—	—	—	—	—	—	—	
10	250	1-8 UNC	10.00	254	16	—	—	—	—	—	—	—	—	—	
12	300	1½-8 UN	10.75	273	16	—	—	—	—	—	—	—	—	—	
14	350	1½-8 UN	12.25	311	16	+	5.50	140	4	5.00	127	4	5.00	127	4
16	400	1¼-8 UN	13.50	343	16	+	5.75	146	4	5.50	140	4	5.50	140	4
18	450	1¼-8 UN	14.25	362	20	+	6.25	159	4	5.50	140	4	5.50	140	4
20	500	1¼-8 UN	15.00	381	20	+	6.25	159	4	5.75	146	4	5.75	146	4
24	600	1½-8 UN	16.75	425	20	+	7.00	178	4	6.50	165	4	6.50	165	4
30	750	1¾-8 UN	21.00	533	24	+	8.25	210	4	7.75	197	4	7.75	197	4
36	900	2-8 UN	24.25	616	28	+	9.25	235	4	9.00	229	4	9.00	229	4

ASME CLASS 300 | SERIES 43 LUG STYLE | STUD LENGTH

Valve Size			Fastener Size			Retainer Side Stud			Back Side Stud			Retainer Blind Stud			Back Blind Stud			
NPS	DN	Ø-Thread	in	mm	Qty	in	mm	Qty	in	mm	Qty	in	mm	Qty	in	mm	Qty	
2½	65	¾-10 UNC	3.25	83	8	3.00	76	8	—	—	—	—	—	—	—	—	—	
3	80	¾-10 UNC	3.25	83	8	3.00	76	8	—	—	—	—	—	—	—	—	—	
4	100	¾-10 UNC	3.25	83	8	3.25	83	8	—	—	—	—	—	—	—	—	—	
5	125	¾-10 UNC	3.75	95	8	3.25	83	8	—	—	—	—	—	—	—	—	—	
6	150	¾-10 UNC	3.75	95	12	3.50	89	12	—	—	—	—	—	—	—	—	—	
8	200	7/8-9 UNC	4.25	108	12	4.00	102	12	—	—	—	—	—	—	—	—	—	
10	250	1-8 UNC	5.00	127	16	4.25	108	16	—	—	—	—	—	—	—	—	—	
12	300	1½-8 UN	5.50	140	16	4.75	121	16	—	—	—	—	—	—	—	—	—	
14	350	1½-8 UN	5.25	133	16	5.75	146	16	+	5.25	133	4	5.00	127	4	5.00	127	4
16	400	1¼-8 UN	5.75	146	16	6.50	165	16	+	5.75	146	4	5.25	133	4	5.25	133	4
18	450	1¼-8 UN	6.00	152	20	6.00	152	20	+	6.00	152	4	5.50	140	4	5.50	140	4
20	500	1¼-8 UN	6.00	152	20	6.25	159	20	+	6.00	152	4	5.50	140	4	5.50	140	4
24	600	1½-8 UN	6.50	165	20	7.00	178	20	+	6.50	165	4	6.25	159	4	6.25	159	4
30	750	1¾-8 UN	8.00	203	24	9.25	235	24	+	8.00	203	4	7.75	197	4	7.75	197	4
36	900	2-8 UN	8.75	222	28	10.50	267	28	+	8.75	222	4	8.75	222	4	8.75	222	4
40	1000	1½-8 UN	9.00	229	28	9.75	248	28	+	9.00	229	4	7.75	197	4	7.75	197	4
42	1050	1½-8 UN	9.75	248	28	8.50	216	28	+	9.75	248	4	8.00	203	4	8.00	203	4
44	1100	1¾-8 UN	9.00	229	28	8.75	222	28	+	9.00	229	4	8.75	222	4	8.75	222	4
48	1200	1¾-8 UN	11.50	292	28	10.00	254	28	+	11.50	292	4	9.50	241	4	9.50	241	4
54	1350	2¼-8 UN	12.50	318	24	11.50	292	24	+	12.50	318	4	11.00	279	4	11.00	279	4

ASME CLASS 300 | SERIES 43 LUG STYLE | BOLT LENGTH

Valve Size			Fastener Size			Retainer Side Hex Head Bolt			Back Side Hex Head Bolt			Retainer Blind Hex Head Bolt			Back Blind Hex Head Bolt			
NPS	DN	Ø-Thread				in	mm	Qty	in	mm	Qty	in	mm	Qty	in	mm	Qty	
2½	65	¾-10 UNC				2.25	57	8	2.00	51	8	—	—	—	—	—	—	
3	80	¾-10 UNC				2.25	57	8	2.25	57	8	—	—	—	—	—	—	
4	100	¾-10 UNC				2.50	64	8	2.25	57	8	—	—	—	—	—	—	
5	125	¾-10 UNC				2.75	70	8	2.50	64	8	—	—	—	—	—	—	
6	150	¾-10 UNC				3.00	76	12	2.75	70	12	—	—	—	—	—	—	
8	200	7/8-9 UNC				3.25	83	12	3.00	76	12	—	—	—	—	—	—	
10	250	1-8 UNC				4.00	102	16	3.25	83	16	—	—	—	—	—	—	
12	300	1½-8 UN				4.25	108	16	3.50	89	16	—	—	—	—	—	—	
14	350	1½-8 UN				4.25	108	16	4.75	121	16	+	4.00	102	4	3.50	89	4
16	400	1¼-8 UN				4.50	114	16	5.25	133	16	+	4.00	102	4	3.75	95	4
18	450	1¼-8 UN				4.75	121	20	5.00	127	20	+	4.50	114	4	3.75	95	4
20	500	1¼-8 UN				4.75	121	20	5.00	127	20	+	4.50	114	4	4.00	102	4
24	600	1½-8 UN				5.25	133	20	5.50	140	20	+	4.75	121	4	4.50	114	4
30	750	1¾-8 UN				6.25	159	24	7.50	191	24	+	5.75	146	4	5.50	140	4
36	900	2-8 UN				7.00	178	28	8.50	216	28	+	6.75	171	4	6.50	165	4
40	1000	1½-8 UN				8.00	203	28	8.75	222	28	+	8.00	203	4	6.75	171	4
42	1050	1½-8 UN				8.75	222	28	7.50	191	28	+	8.50	216	4	6.75	171	4
44	1100	1¾-8 UN				7.25	184	28	7.00	178	28	+	7.00	178	4	7.00	178	4
48	1200	1¾-8 UN				9.50	241	28	8.00	203	28	+	9.25	235	4	7.25	184	4
54	1350	2¼-8 UN				10.25	260	24	9.25	235	24	+	9.75	248	4	8.50	216	4

ASME CLASS 300 | SERIES 4B DOUBLE FLANGE STYLE | BOLT LENGTH

Valve Size			Fastener Size			Retainer Hex Head Bolt			Back Side Hex Head Bolt			Retainer Blind Hex Head Bolt			
NPS	DN	Ø-Thread				in	mm	Qty	in	mm	Qty	in	mm	Qty	
3	80	¾-10 UNC				2.25	57	8	3.75	95	8	—	—	—	
4	100	¾-10 UNC				2.50	64	8	4.00	102	8	—	—	—	
5	125	¾-10 UNC				2.50	64	8	4.25	108	8	—	—	—	
6	150	¾-10 UNC				2.75	70	12	4.25	108	12	—	—	—	
8	200	7/8-9 UNC				3.00	76	12	4.75	121	12	—	—	—	
10	250	1-8 UNC				3.50	89	12	5.50	140	12	+	3.50	89	8
12	300	1½-8 UN				3.75	95	12	6.00	152	12	+	3.75	95	8
14	350	1½-8 UN				3.75	95	16	6.00	152	16	+	3.75	95	8
16	400	1¼-8 UN				4.00	102	16	6.50	165	16	+	4.00	102	8
18	450	1¼-8 UN				4.25	108	20	6.75	171	20	+	4.25	108	8
20	500	1¼-8 UN				4.25	108	20	7.00	178	20	+	4.25	108	8
24	600	1½-8 UN				4.75	121	20	7.75	197	20	+	4.75	121	8
30	750	1¾-8 UN				6.00	152	24	9.75	248	24	+	6.00	152	8
36	900	2-8 UN				6.75	171	28	11.00	279	28	+	6.75	171	8

ASME CLASS 600 | SERIES 44 WAFER STYLE | THRU STUD LENGTH

Valve Size			Fastener Size			Thru Stud			Retainer Blind Stud			Back Blind Stud			
NPS	DN	Ø-Thread	in	mm	Qty	in	mm	Qty	in	mm	Qty	in	mm	Qty	
3	80	3/4-10 UNC	7.25	184	8	—	—	—	—	—	—	—	—	—	
4	100	7/8-9 UNC	8.50	216	8	—	—	—	—	—	—	—	—	—	
6	150	1-8 UNC	10.25	260	12	—	—	—	—	—	—	—	—	—	
8	200	1 1/8-8 UN	12.00	305	12	—	—	—	—	—	—	—	—	—	
10	250	1 1/4-8 UN	13.50	343	12	+	6.25	159	4	5.75	146	4	5.75	146	4
12	300	1 1/4-8 UN	14.50	368	16	+	6.25	159	4	5.75	146	4	5.75	146	4
14	350	1 3/8-8 UN	15.50	394	16	+	6.50	165	4	6.00	152	4	6.00	152	4
16	400	1 1/2-8 UN	17.25	438	16	+	6.75	171	4	6.50	165	4	6.50	165	4
18	450	1 5/8-8 UN	18.75	476	16	+	7.50	191	4	7.00	178	4	7.00	178	4
20	500	1 3/4-8 UN	20.00	508	20	+	8.00	203	4	7.25	184	4	7.25	184	4
24	600	1 7/8-8 UN	22.25	565	20	+	8.75	222	4	8.50	216	4	8.50	216	4

ASME CLASS 600 | SERIES 45 LUG STYLE | STUD LENGTH

Valve Size			Fastener Size			Retainer Side Stud			Back Side Stud			Retainer Blind Stud			Back Blind Stud			
NPS	DN	Ø-Thread	in	mm	Qty	in	mm	Qty	in	mm	Qty	in	mm	Qty	in	mm	Qty	
3	80	3/4-10 UNC	4.00	102	8	3.50	89	8	—	—	—	—	—	—	—	—	—	
4	100	7/8-9 UNC	4.50	114	8	4.00	102	8	—	—	—	—	—	—	—	—	—	
6	150	1-8 UNC	5.00	127	12	4.50	114	12	—	—	—	—	—	—	—	—	—	
8	200	1 1/8-8 UN	5.75	146	12	5.25	133	12	—	—	—	—	—	—	—	—	—	
10	250	1 1/4-8 UN	6.25	159	12	5.75	146	12	+	6.25	159	4	5.50	140	4	5.50	140	4
12	300	1 1/4-8 UN	6.25	159	16	5.75	146	16	+	6.25	159	4	5.75	146	4	5.75	146	4
14	350	1 3/8-8 UN	6.50	165	16	6.25	159	16	+	6.50	165	4	6.25	159	4	6.25	159	4
16	400	1 1/2-8 UN	7.00	178	16	6.75	171	16	+	6.75	171	4	6.50	165	4	6.50	165	4
18	450	1 5/8-8 UN	7.75	197	16	7.25	184	16	+	7.75	197	4	7.25	184	4	7.25	184	4
20	500	1 3/4-8 UN	8.25	210	20	7.50	191	20	+	8.25	210	4	7.50	191	4	7.50	191	4
24	600	1 7/8-8 UN	8.75	222	20	8.50	216	20	+	8.50	216	4	8.25	210	4	8.25	210	4

ASME CLASS 600 | SERIES 45 LUG STYLE | BOLT LENGTH

Valve Size			Fastener Size			Retainer Side Hex Head Bolt			Back Side Hex Head Bolt			Retainer Blind Hex Head Bolt			Back Blind Hex Head Bolt			
NPS	DN	Ø-Thread	in	mm	Qty	in	mm	Qty	in	mm	Qty	in	mm	Qty	in	mm	Qty	
3	80	3/4-10 UNC	2.75	70	8	2.50	64	8	—	—	—	—	—	—	—	—	—	
4	100	7/8-9 UNC	3.25	83	8	2.75	70	8	—	—	—	—	—	—	—	—	—	
6	150	1-8 UNC	3.75	95	12	3.25	83	12	—	—	—	—	—	—	—	—	—	
8	200	1 1/8-8 UN	4.25	108	12	3.75	95	12	—	—	—	—	—	—	—	—	—	
10	250	1 1/4-8 UN	4.75	121	12	4.00	102	12	+	4.50	114	4	4.00	102	4	4.00	102	4
12	300	1 1/4-8 UN	4.75	121	16	4.25	108	16	+	4.50	114	4	4.00	102	4	4.00	102	4
14	350	1 3/8-8 UN	5.00	127	16	4.50	114	16	+	4.75	121	4	4.50	114	4	4.50	114	4
16	400	1 1/2-8 UN	5.00	127	16	5.00	127	16	+	5.00	127	4	4.75	121	4	4.75	121	4
18	450	1 5/8-8 UN	5.75	146	16	5.25	133	16	+	5.50	140	4	5.00	127	4	5.00	127	4
20	500	1 3/4-8 UN	6.25	159	20	5.50	140	20	+	6.25	159	4	5.25	133	4	5.25	133	4
24	600	1 7/8-8 UN	6.50	165	20	6.50	165	20	+	6.50	165	4	6.00	152	4	6.00	152	4

WAFER VALVE WITH THRU STUDS

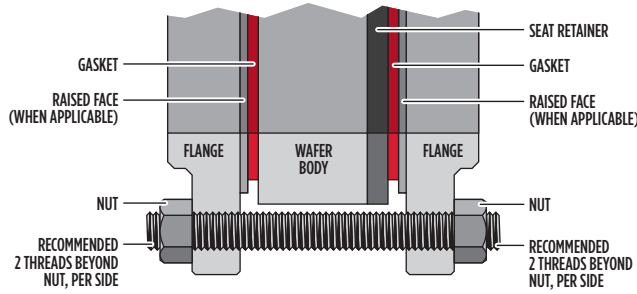

THRU STUD LENGTH								
Nut Thickness (X2)	+	Flange Thickness (X2)	+	Gasket Thickness (X2)	+	Valve Face to Face	=	Length of Stud
PLUS 2 THREADS PER NUT		INCLUDE RAISED FACE, IF APPLICABLE				INCLUDE SEAT RETAINER		

LUG VALVE WITH STUDS

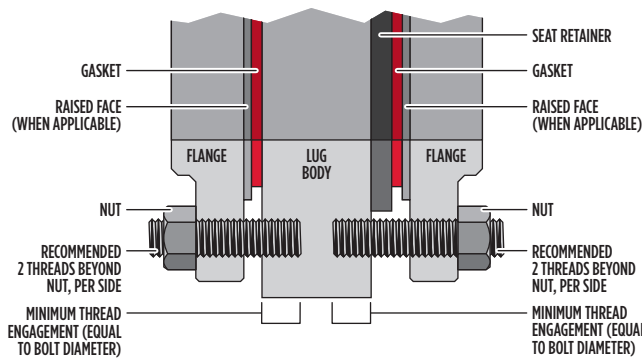

STUD LENGTH										
Nut Thickness	+	Flange Thickness	+	Gasket Thickness	+	Seat Retainer Ring Raised Face	+	Minimum Thread Engagement	=	Length of Stud
PLUS 2 THREADS PER NUT		INCLUDE RAISED FACE, IF APPLICABLE				SEAT RETAINER SIDE ONLY		ONE BOLT DIAMETER		

LUG VALVE WITH HEX HEAD BOLTS

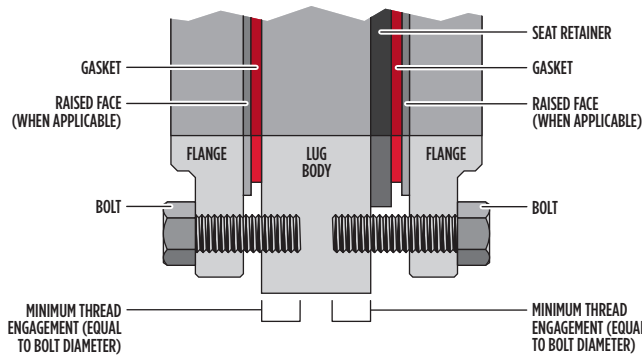

HEX HEAD BOLT LENGTH								
Flange Thickness	+	Gasket Thickness	+	Seat Retainer Ring Raised Face	+	Minimum Thread Engagement	=	Length of Bolt
INCLUDE RAISED FACE, IF APPLICABLE				SEAT RETAINER SIDE ONLY		ONE BOLT DIAMETER		

IMPORTANT INFORMATION

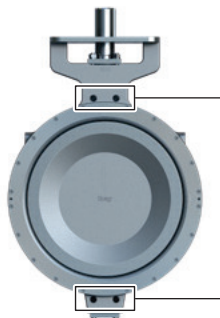

CAUTION
Tapped holes at neck locations do not permit through-holes.

NOTES

- > Double flange style bolting not shown.
- > Refer to appropriate Bray dimensional drawings for specific valve drilling information.
- > Lug threads may be tapped from both sides, and therefore tap may not be continuous.
- > Minimum bolt engagement must be equal to the diameter of the bolt.
- > When bolting the valve into the line, use standard bolting torque as recommended by applicable piping standards. Additional force from the flange bolts is not required.

ASSUMPTIONS MADE IN CALCULATIONS

- > Lengths rounded to the nearest 1/4 inch for maximum thread engagement.
- > Nut thickness as per ASME B18.2.2 Heavy Hex.
- > Flange thickness as per ASME B16.5 or ASME B16.47 Series A.
- > Gasket thickness = .175 inch.
- > Raised face = .06 inch.

ASME CLASS 150 | SERIES 40 WAFER STYLE | THRU STUD LENGTH

Valve Size			Fastener Size			Thru Stud			Retainer Blind Stud			Back Blind Stud		
NPS	DN	Ø-Thread	in	mm	Qty	in	mm	Qty	in	mm	Qty	in	mm	Qty
2	50	5/8-11 UNC	5.25	133	4	—	—	—	—	—	—	—	—	—
2½	65	5/8-11 UNC	5.75	146	4	—	—	—	—	—	—	—	—	—
3	80	5/8-11 UNC	5.75	146	4	—	—	—	—	—	—	—	—	—
4	100	5/8-11 UNC	6.00	152	8	—	—	—	—	—	—	—	—	—
5	125	¾-10 UNC	6.50	165	8	—	—	—	—	—	—	—	—	—
6	150	¾-10 UNC	6.50	165	8	—	—	—	—	—	—	—	—	—
8	200	¾-10 UNC	7.00	178	8	—	—	—	—	—	—	—	—	—
10	250	7/8-9 UNC	7.75	197	12	—	—	—	—	—	—	—	—	—
12	300	7/8-9 UNC	8.25	210	12	—	—	—	—	—	—	—	—	—
14	350	1-8 UNC	9.50	241	12	—	—	—	—	—	—	—	—	—
16	400	1-8 UNC	10.00	254	16	—	—	—	—	—	—	—	—	—
18	450	1 1/8-8 UN	11.00	279	16	—	—	—	—	—	—	—	—	—
20	500	1 1/8-8 UN	11.50	292	16	+	5.25	133	4	4.50	114	4	—	—
24	600	1 1/4-8 UN	13.00	330	20	+	—	—	—	—	—	—	—	—
26	650	1 1/4-8 UN	15.50	394	20	+	6.75	171	4	5.75	146	4	—	—
28	700	1 1/4-8 UN	15.50	394	24	+	6.50	165	4	5.75	146	4	—	—
30	750	1 1/4-8 UN	16.75	425	24	+	7.25	184	4	6.00	152	4	—	—
32	800	1 1/4-8 UN	17.75	451	24	+	7.75	197	4	6.75	171	4	—	—
36	900	1 1/2-8 UN	19.25	489	28	+	8.00	203	4	7.00	178	4	—	—
42	1050	1 1/2-8 UN	21.00	533	32	+	8.00	203	4	7.25	184	4	—	—
48	1200	1 1/2-8 UN	22.50	572	40	+	8.25	210	4	7.75	197	4	—	—
54	1350	1 3/4-8 UN	24.75	629	40	+	10.00	254	4	8.75	222	4	—	—

ASME CLASS 150 | SERIES 41 LUG STYLE | STUD LENGTH

Valve Size			Fastener Size			Retainer Side Stud			Back Side Stud			Retainer Blind Stud			Back Blind Stud		
NPS	DN	Ø-Thread	in	mm	Qty	in	mm	Qty	in	mm	Qty	in	mm	Qty	in	mm	Qty
2½	65	5/8-11 UNC	2.75	70	4	2.50	64	4	—	—	—	—	—	—	—	—	—
3	80	5/8-11 UNC	2.75	70	4	2.50	64	4	—	—	—	—	—	—	—	—	—
4	100	5/8-11 UNC	3.00	76	8	2.50	64	8	—	—	—	—	—	—	—	—	—
5	125	¾-10 UNC	3.00	76	8	2.75	70	8	—	—	—	—	—	—	—	—	—
6	150	¾-10 UNC	3.25	83	8	2.75	70	8	—	—	—	—	—	—	—	—	—
8	200	¾-10 UNC	3.50	89	8	3.00	76	8	—	—	—	—	—	—	—	—	—
10	250	7/8-9 UNC	3.75	95	12	3.50	89	12	—	—	—	—	—	—	—	—	—
12	300	7/8-9 UNC	4.00	102	12	3.75	95	12	—	—	—	—	—	—	—	—	—
14	350	1-8 UNC	4.75	121	12	4.00	102	12	—	—	—	—	—	—	—	—	—
16	400	1-8 UNC	4.50	114	16	4.50	114	16	—	—	—	—	—	—	—	—	—
18	450	1 1/8-8 UN	5.25	133	16	5.00	127	16	—	—	—	—	—	—	—	—	—
20	500	1 1/8-8 UN	5.25	133	16	5.25	133	16	+	5.25	133	4	4.25	108	4	—	—
24	600	1 1/4-8 UN	6.00	152	20	5.75	146	20	+	—	—	—	—	—	—	—	—
28	700	1 1/4-8 UN	6.50	165	24	6.75	171	24	+	6.50	165	4	5.75	146	4	—	—
30	750	1 1/4-8 UN	7.25	184	24	6.75	171	24	+	7.25	184	4	5.75	146	4	—	—
32	800	1 1/2-8 UN	7.75	197	24	7.75	197	24	+	7.75	197	4	6.50	165	4	—	—
36	900	1 1/2-8 UN	8.00	203	28	8.00	203	28	+	8.00	203	4	7.00	178	4	—	—
40	1000	1 1/2-8 UN	7.75	197	32	8.50	216	32	+	7.75	197	4	7.00	178	4	—	—
42	1050	1 1/2-8 UN	7.75	197	32	9.00	229	32	+	7.75	197	4	7.25	184	4	—	—
48	1200	1 1/2-8 UN	8.00	203	40	9.25	235	40	+	8.00	203	4	7.75	197	4	—	—
54	1350	1 3/4-8 UN	9.25	235	40	10.25	260	40	+	9.25	235	4	8.25	210	4	—	—
60	1500	1 3/4-8 UN	10.00	254	42	9.00	229	42	+	10.00	254	10	9.00	229	10	—	—

ASME CLASS 150 | SERIES 41 LUG STYLE | BOLT LENGTH

Valve Size			Fastener Size			Retainer Side Hex Head Bolt			Back Side Hex Head Bolt			Retainer Blind Hex Head Bolt			Back Blind Hex Head Bolt		
NPS	DN	Ø-Thread	in	mm	Qty	in	mm	Qty	in	mm	Qty	in	mm	Qty	in	mm	Qty
2 1/2	65	5/8-11 UNC	2.00	51	4	1.75	44	4	—	—	—	—	—	—	—	—	—
3	80	5/8-11 UNC	2.00	51	4	1.75	44	4	—	—	—	—	—	—	—	—	—
4	100	5/8-11 UNC	2.25	57	8	1.75	44	8	—	—	—	—	—	—	—	—	—
5	125	3/4-10 UNC	2.25	57	8	2.00	51	8	—	—	—	—	—	—	—	—	—
6	150	3/4-10 UNC	2.25	57	8	2.00	51	8	—	—	—	—	—	—	—	—	—
8	200	3/4-10 UNC	2.50	64	8	2.25	57	8	—	—	—	—	—	—	—	—	—
10	250	7/8-9 UNC	2.75	70	12	2.50	64	12	—	—	—	—	—	—	—	—	—
12	300	7/8-9 UNC	3.00	76	12	2.75	70	12	—	—	—	—	—	—	—	—	—
14	350	1-8 UNC	3.50	89	12	3.00	76	12	—	—	—	—	—	—	—	—	—
16	400	1-8 UNC	3.50	89	16	3.50	89	16	—	—	—	—	—	—	—	—	—
18	450	1 1/8-8 UN	4.00	102	16	3.75	95	16	—	—	—	—	—	—	—	—	—
20	500	1 1/8-8 UN	4.00	102	16	4.25	108	16	+	4.00	102	4	3.25	83	4	—	—
24	600	1 1/4-8 UN	4.75	121	20	4.50	114	20	+	—	—	—	—	—	—	—	—
28	700	1 1/4-8 UN	5.25	133	24	5.50	140	24	+	5.25	133	4	4.25	108	4	—	—
30	750	1 1/4-8 UN	6.00	152	24	5.50	140	24	+	5.75	146	4	4.50	114	4	—	—
32	800	1 1/2-8 UN	6.25	159	24	6.25	159	24	+	5.75	146	4	4.75	121	4	—	—
36	900	1 1/2-8 UN	6.50	165	28	6.50	165	28	+	6.25	159	4	5.25	133	4	—	—
40	1000	1 1/2-8 UN	6.25	159	32	7.00	178	32	+	5.75	146	4	5.00	127	4	—	—
42	1050	1 1/2-8 UN	6.25	159	32	7.50	191	32	+	6.00	152	4	5.50	140	4	—	—
48	1200	1 1/2-8 UN	6.50	165	40	7.75	197	40	+	6.50	165	4	6.00	152	4	—	—
54	1350	1 3/4-8 UN	7.50	191	40	8.50	216	40	+	7.00	178	4	6.25	159	4	—	—
60	1500	1 3/4-8 UN	8.25	210	42	7.25	184	42	+	8.00	203	10	6.75	171	10	—	—

ASME CLASS 150 | SERIES 4A DOUBLE FLANGE STYLE | BOLT LENGTH

Valve Size			Fastener Size			Retainer Side Hex Head Bolt			Back Side Hex Head Bolt			Retainer Blind Hex Head Bolt		
NPS	DN	Ø-Thread	in	mm	Qty	in	mm	Qty	in	mm	Qty	in	mm	Qty
3	80	5/8-11 UNC	3.25	83	4	3.00	76	4	—	—	—	—	—	—
4	100	5/8-11 UNC	3.50	89	6	3.00	76	8	+	2.00	51	2	—	—
5	125	3/4-10 UNC	3.50	89	6	3.00	76	8	+	2.25	57	2	—	—
6	150	3/4-10 UNC	3.75	95	6	3.25	83	8	+	2.25	57	2	—	—
8	200	3/4-10 UNC	4.00	102	6	3.50	89	8	+	2.50	64	2	—	—
10	250	7/8-9 UNC	4.25	108	10	3.75	95	12	+	2.75	70	2	—	—
12	300	7/8-9 UNC	4.50	114	8	3.75	95	12	+	2.75	70	4	—	—
14	350	1-8 UNC	5.00	127	8	4.25	108	12	+	3.00	76	4	—	—
16	400	1-8 UNC	5.00	127	12	4.25	108	16	+	3.00	76	4	—	—
18	450	1 1/8-8 UN	5.50	140	12	4.75	121	16	+	3.25	83	4	—	—
20	500	1 1/8-8 UN	5.75	146	16	5.00	127	20	+	3.50	89	4	—	—
24	600	1 1/4-8 UN	6.50	165	16	5.50	140	20	+	3.75	95	4	—	—
30	750	1 1/4-8 UN	9.25	235	24	7.50	191	28	+	5.00	127	4	—	—

ASME CLASS 300 | SERIES 42 WAFER STYLE | THRU STUD LENGTH

Valve Size			Fastener Size			Thru Stud			Retainer Blind Stud			Back Blind Stud			
NPS	DN	Ø-Thread	in	mm	Qty	in	mm	Qty	in	mm	Qty	in	mm	Qty	
2½	65	¾-10 UNC	6.00	152	8	—	—	—	—	—	—	—	—	—	
3	80	¾-10 UNC	6.25	159	8	—	—	—	—	—	—	—	—	—	
4	100	¾-10 UNC	6.75	171	8	—	—	—	—	—	—	—	—	—	
5	125	¾-10 UNC	7.25	184	8	—	—	—	—	—	—	—	—	—	
6	150	¾-10 UNC	7.50	191	12	—	—	—	—	—	—	—	—	—	
8	200	7/8-9 UNC	8.50	216	12	—	—	—	—	—	—	—	—	—	
10	250	1-8 UNC	9.75	248	16	—	—	—	—	—	—	—	—	—	
12	300	1½-8 UN	10.50	267	16	—	—	—	—	—	—	—	—	—	
14	350	1½-8 UN	12.00	305	16	+	5.50	140	4	5.00	127	4	5.00	127	4
16	400	1¼-8 UN	13.25	337	16	+	5.50	140	4	5.25	133	4	5.25	133	4
18	450	1¼-8 UN	14.00	356	20	+	6.25	159	4	5.50	140	4	5.50	140	4
20	500	1¼-8 UN	14.50	368	20	+	6.25	159	4	5.50	140	4	5.50	140	4
24	600	1½-8 UN	16.50	419	20	+	6.75	171	4	6.25	159	4	6.25	159	4
30	750	1¾-8 UN	20.50	521	24	+	8.00	203	4	7.75	197	4	7.75	197	4
36	900	2-8 UN	24.00	610	28	+	9.00	229	4	8.75	222	4	8.75	222	4

ASME CLASS 300 | SERIES 43 LUG STYLE | STUD LENGTH

Valve Size			Fastener Size			Retainer Side Stud			Back Side Stud			Retainer Blind Stud			Back Blind Stud			
NPS	DN	Ø-Thread	in	mm	Qty	in	mm	Qty	in	mm	Qty	in	mm	Qty	in	mm	Qty	
2½	65	¾-10 UNC	3.00	76	8	2.75	70	8	—	—	—	—	—	—	—	—	—	
3	80	¾-10 UNC	3.25	83	8	3.00	76	8	—	—	—	—	—	—	—	—	—	
4	100	¾-10 UNC	3.25	83	8	3.00	76	8	—	—	—	—	—	—	—	—	—	
5	125	¾-10 UNC	3.50	89	8	3.25	83	8	—	—	—	—	—	—	—	—	—	
6	150	¾-10 UNC	3.75	95	12	3.50	89	12	—	—	—	—	—	—	—	—	—	
8	200	7/8-9 UNC	4.25	108	12	3.75	95	12	—	—	—	—	—	—	—	—	—	
10	250	1-8 UNC	4.75	121	16	4.25	108	16	—	—	—	—	—	—	—	—	—	
12	300	1½-8 UN	5.25	133	16	4.50	114	16	—	—	—	—	—	—	—	—	—	
14	350	1½-8 UN	5.00	127	16	5.75	146	16	+	5.00	127	4	4.75	121	4	4.75	121	4
16	400	1¼-8 UN	5.50	140	16	6.50	165	16	+	5.50	140	4	5.00	127	4	5.00	127	4
18	450	1¼-8 UN	6.00	152	20	6.00	152	20	+	6.00	152	4	5.25	133	4	5.25	133	4
20	500	1¼-8 UN	6.00	152	20	6.00	152	20	+	6.00	152	4	5.25	133	4	5.25	133	4
24	600	1½-8 UN	6.50	165	20	6.75	171	20	+	6.50	165	4	6.00	152	4	6.00	152	4
30	750	1¾-8 UN	7.75	197	24	9.00	229	24	+	7.75	197	4	7.50	191	4	7.50	191	4
36	900	2-8 UN	8.75	222	28	10.25	260	28	+	8.75	222	4	8.50	216	4	8.50	216	4
40	1000	1½-8 UN	9.00	229	28	9.75	248	28	+	9.00	229	4	7.75	197	4	7.75	197	4
42	1050	1½-8 UN	9.50	241	28	8.25	210	28	+	9.50	241	4	7.75	197	4	7.75	197	4
44	1100	1¾-8 UN	8.75	222	28	8.75	222	28	+	8.75	222	4	8.75	222	4	8.75	222	4
48	1200	1¾-8 UN	11.25	286	28	9.75	248	28	+	11.25	286	4	9.25	235	4	9.25	235	4
54	1350	2¼-8 UN	12.25	311	24	11.25	286	24	+	12.25	311	4	10.75	273	4	10.75	273	4

ASME CLASS 300 | SERIES 43 LUG STYLE | BOLT LENGTH

Valve Size			Fastener Size			Retainer Side Hex Head Bolt			Back Side Hex Head Bolt			Retainer Blind Hex Head Bolt			Back Blind Hex Head Bolt		
NPS	DN	Ø-Thread	in	mm	Qty	in	mm	Qty	in	mm	Qty	in	mm	Qty	in	mm	Qty
2½	65	¾-10 UNC	2.25	57	8	1.75	44	8	—	—	—	—	—	—	—	—	—
3	80	¾-10 UNC	2.25	57	8	2.00	51	8	—	—	—	—	—	—	—	—	—
4	100	¾-10 UNC	2.25	57	8	2.25	57	8	—	—	—	—	—	—	—	—	—
5	125	¾-10 UNC	2.75	70	8	2.25	57	8	—	—	—	—	—	—	—	—	—
6	150	¾-10 UNC	2.75	70	12	2.50	64	12	—	—	—	—	—	—	—	—	—
8	200	7/8-9 UNC	3.25	83	12	2.75	70	12	—	—	—	—	—	—	—	—	—
10	250	1-8 UNC	3.75	95	16	3.25	83	16	—	—	—	—	—	—	—	—	—
12	300	1⅛-8 UN	4.25	108	16	3.50	89	16	—	—	—	—	—	—	—	—	—
14	350	1⅛-8 UN	4.00	102	16	4.50	114	16	+	3.75	95	4	3.25	83	4	—	—
16	400	1¼-8 UN	4.25	108	16	5.25	133	16	+	4.00	102	4	3.50	89	4	—	—
18	450	1¼-8 UN	4.75	121	20	4.75	121	20	+	4.50	114	4	3.75	95	4	—	—
20	500	1¼-8 UN	4.75	121	20	4.75	121	20	+	4.50	114	4	4.00	102	4	—	—
24	600	1½-8 UN	5.00	127	20	5.25	133	20	+	4.75	121	4	4.50	114	4	—	—
30	750	1¾-8 UN	6.00	152	24	7.25	184	24	+	5.75	146	4	5.50	140	4	—	—
36	900	2-8 UN	6.75	171	28	8.25	210	28	+	6.50	165	4	6.50	165	4	—	—
40	1000	1⅝-8 UN	7.75	197	28	8.50	216	28	+	7.75	197	4	6.50	165	4	—	—
42	1050	1⅝-8 UN	8.50	216	28	7.25	184	28	+	8.25	210	4	6.50	165	4	—	—
44	1100	1¾-8 UN	7.00	178	28	7.00	178	28	+	7.00	178	4	6.75	171	4	—	—
48	1200	1⅞-8 UN	9.50	241	28	8.00	203	28	+	9.25	235	4	7.25	184	4	—	—
54	1350	2¼-8 UN	10.00	254	24	9.00	229	24	+	9.75	248	4	8.25	210	4	—	—

ASME CLASS 300 | SERIES 4B DOUBLE FLANGE STYLE | BOLT LENGTH

Valve Size			Fastener Size			Retainer Hex Head Bolt			Back Side Hex Head Bolt			Retainer Blind Hex Head Bolt		
NPS	DN	Ø-Thread	in	mm	Qty	in	mm	Qty	in	mm	Qty	in	mm	Qty
3	80	¾-10 UNC	2.25	57	8	3.50	89	8	—	—	—	—	—	—
4	100	¾-10 UNC	2.25	57	8	3.75	95	8	—	—	—	—	—	—
5	125	¾-10 UNC	2.50	64	12	4.00	102	12	—	—	—	—	—	—
6	150	¾-10 UNC	2.50	64	12	4.25	108	12	—	—	—	—	—	—
8	200	7/8-9 UNC	2.75	70	12	4.75	121	12	—	—	—	—	—	—
10	250	1-8 UNC	3.25	83	16	5.25	133	16	+	3.25	83	8	—	—
12	300	1⅛-8 UN	3.50	89	16	5.75	146	16	+	3.50	89	8	—	—
14	350	1⅛-8 UN	3.50	89	16	6.00	152	16	+	3.50	89	8	—	—
16	400	1¼-8 UN	3.75	95	16	6.25	159	16	+	3.75	95	8	—	—
18	450	1¼-8 UN	4.00	102	20	6.50	165	20	+	4.00	102	8	—	—
20	500	1¼-8 UN	4.00	102	20	6.75	171	20	+	4.00	102	8	—	—
24	600	1½-8 UN	4.50	114	20	7.50	191	20	+	4.50	114	8	—	—
30	750	1¾-8 UN	6.00	152	24	9.75	248	24	+	6.00	152	8	—	—
36	900	2-8 UN	6.50	165	28	10.75	273	28	+	6.50	165	8	—	—

ASME CLASS 600 | SERIES 44 WAFER STYLE | THRU STUD LENGTH

Valve Size			Fastener Size			Thru Stud			Retainer Blind Stud			Back Blind Stud		
NPS	DN	Ø-Thread	in	mm	Qty	in	mm	Qty	in	mm	Qty	in	mm	Qty
3	80	3/4-10 UNC	7.00	178	8	—	—	—	—	—	—	—	—	—
4	100	7/8-9 UNC	8.25	210	8	—	—	—	—	—	—	—	—	—
6	150	1-8 UNC	10.00	254	12	—	—	—	—	—	—	—	—	—
8	200	1 1/8-8 UN	11.75	298	12	—	—	—	—	—	—	—	—	—
10	250	1 1/4-8 UN	13.25	337	12	+	6.00	152	4	5.50	140	4	4	4
12	300	1 1/4-8 UN	14.00	356	16	+	6.00	152	4	5.50	140	4	4	4
14	350	1 3/8-8 UN	15.25	387	16	+	6.25	159	4	6.00	152	4	4	4
16	400	1 1/2-8 UN	17.00	432	16	+	6.75	171	4	6.50	165	4	4	4
18	450	1 5/8-8 UN	18.50	470	16	+	7.50	191	4	7.00	178	4	4	4
20	500	1 3/4-8 UN	19.75	502	20	+	8.00	203	4	7.25	184	4	4	4
24	600	1 7/8-8 UN	21.75	552	20	+	8.50	216	4	8.25	210	4	4	4

ASME CLASS 600 | SERIES 45 LUG STYLE | STUD LENGTH

Valve Size			Fastener Size			Retainer Side Stud			Back Side Stud			Retainer Blind Stud			Back Blind Stud		
NPS	DN	Ø-Thread	in	mm	Qty	in	mm	Qty	in	mm	Qty	in	mm	Qty	in	mm	Qty
3	80	3/4-10 UNC	3.75	95	8	3.25	83	8	—	—	—	—	—	—	—	—	—
4	100	7/8-9 UNC	4.25	108	8	3.75	95	8	—	—	—	—	—	—	—	—	—
6	150	1-8 UNC	4.75	121	12	4.50	114	12	—	—	—	—	—	—	—	—	—
8	200	1 1/8-8 UN	5.50	140	12	5.00	127	12	—	—	—	—	—	—	—	—	—
10	250	1 1/4-8 UN	6.25	159	12	5.50	140	12	+	6.25	159	4	5.50	140	4	4	4
12	300	1 1/4-8 UN	6.25	159	16	5.75	146	16	+	6.25	159	4	5.75	146	4	4	4
14	350	1 3/8-8 UN	6.50	165	16	6.00	152	16	+	6.50	165	4	6.00	152	4	4	4
16	400	1 1/2-8 UN	6.75	171	16	6.50	165	16	+	6.75	171	4	6.50	165	4	4	4
18	450	1 5/8-8 UN	7.50	191	16	7.00	178	16	+	7.50	191	4	7.00	178	4	4	4
20	500	1 3/4-8 UN	8.00	203	20	7.25	184	20	+	8.00	203	4	7.25	184	4	4	4
24	600	1 7/8-8 UN	8.75	222	20	8.25	210	20	+	8.75	222	4	8.25	210	4	4	4

ASME CLASS 600 | SERIES 45 LUG STYLE | BOLT LENGTH

Valve Size			Fastener Size			Retainer Side Hex Head Bolt			Back Side Hex Head Bolt			Retainer Blind Hex Head Bolt			Back Blind Hex Head Bolt		
NPS	DN	Ø-Thread	in	mm	Qty	in	mm	Qty	in	mm	Qty	in	mm	Qty	in	mm	Qty
3	80	3/4-10 UNC	2.75	70	8	2.25	57	8	—	—	—	—	—	—	—	—	—
4	100	7/8-9 UNC	3.00	76	8	2.75	70	8	—	—	—	—	—	—	—	—	—
6	150	1-8 UNC	3.50	89	12	3.25	83	12	—	—	—	—	—	—	—	—	—
8	200	1 1/8-8 UN	4.25	108	12	3.50	89	12	—	—	—	—	—	—	—	—	—
10	250	1 1/4-8 UN	4.75	121	12	4.00	102	12	+	4.50	114	4	3.75	95	4	4	4
12	300	1 1/4-8 UN	4.75	121	16	4.25	108	16	+	4.50	114	4	4.00	102	4	4	4
14	350	1 3/8-8 UN	4.75	121	16	4.50	114	16	+	4.50	114	4	4.25	108	4	4	4
16	400	1 1/2-8 UN	5.00	127	16	4.75	121	16	+	4.75	116	4	4.50	114	4	4	4
18	450	1 5/8-8 UN	5.75	146	16	5.25	133	16	+	5.50	140	4	5.00	127	4	4	4
20	500	1 3/4-8 UN	6.25	159	20	5.50	140	20	+	6.00	152	4	5.25	133	4	4	4
24	600	1 7/8-8 UN	6.50	165	20	6.25	159	20	+	6.25	159	4	6.00	152	4	4	4

SINCE 1986, BRAY HAS PROVIDED FLOW CONTROL SOLUTIONS FOR A VARIETY OF INDUSTRIES AROUND THE WORLD.

VISIT **BRAY.COM** TO LEARN MORE ABOUT BRAY PRODUCTS AND LOCATIONS NEAR YOU.

HEADQUARTERS

Bray International, Inc.

13333 Westland East Blvd.

Houston, Texas 77041

Tel: +1.281.894.5454

All statements, technical information, and recommendations in this bulletin are for general use only. Consult Bray representatives or factory for the specific requirements and material selection for your intended application. The right to change or modify product design or product without prior notice is reserved. Patents issued and applied for worldwide. Bray® is a registered trademark of Bray International, Inc.

© 2021 BRAY INTERNATIONAL. ALL RIGHTS RESERVED. BRAY.COM

TSG_EN_1023_S4X_20210311



THE HIGH PERFORMANCE COMPANY

BRAY.COM